

A Self-Priming Centrifugal Pumps with open impeller



Construction

Close-coupled centrifugal pumps with open impeller. The built-in backflow preventer avoids reverse siphoning when the pump is stopped and assures automatic re-priming at the next start. The pump re-priming itself even if partially filled with liquid and with completely empty suction pipe.

Applications

For clean or slightly dirty water, also with solids up to 10 mm grain size.
 For draining a basin or a sump.
 For irrigation.
 For civil and industrial applications.

Operating conditions

Liquid temperature from -10 °C to +90 °C.
 Room temperature up to 40 °C.
 Maximum permissible working pressure up to 10 bar.
 Continuous duty.

Motor

2-pole induction motor, 50 Hz (n = 2900 1/min).
A : three-phase 230/400 V ± 10%.
AM: single-phase 230 V ± 10%, with thermal protector. Capacitor inside the terminal box.
 Insulation class F.
 Protection IP 54
 Constructed in accordance with IEC 34.

Materials

Components	A	B-A
Pump casing Suction flange Inspection cover (for A 65-150) Lantern bracket Impeller	Cast iron GJL 200 EN 1561	Bronze G-Cu Sn 10 UNI 7013
Shaft	Chrome-nickel steel 1.4305 EN 10088 (AISI 303) Chrome steel 1.4104 EN 10088 (AISI 430) for A 65-150AE,BE	Cr-Ni-Mo steel 1.4401 EN 10088 (AISI 316)
Mechanical seal	Carbon - Ceramic - NBR	

Special features on request

Other voltages.
 Frequency 60 Hz (as per 60 Hz data sheet).
 Protection IP 55.
 Special mechanical seal.
 Higher or lower liquid or ambient temperatures.
 Close-coupled construction with explosion proof motor EEx d II B T4.
 Construction with bearing bracket.

Coverage chart n ≈ 2900 rpm

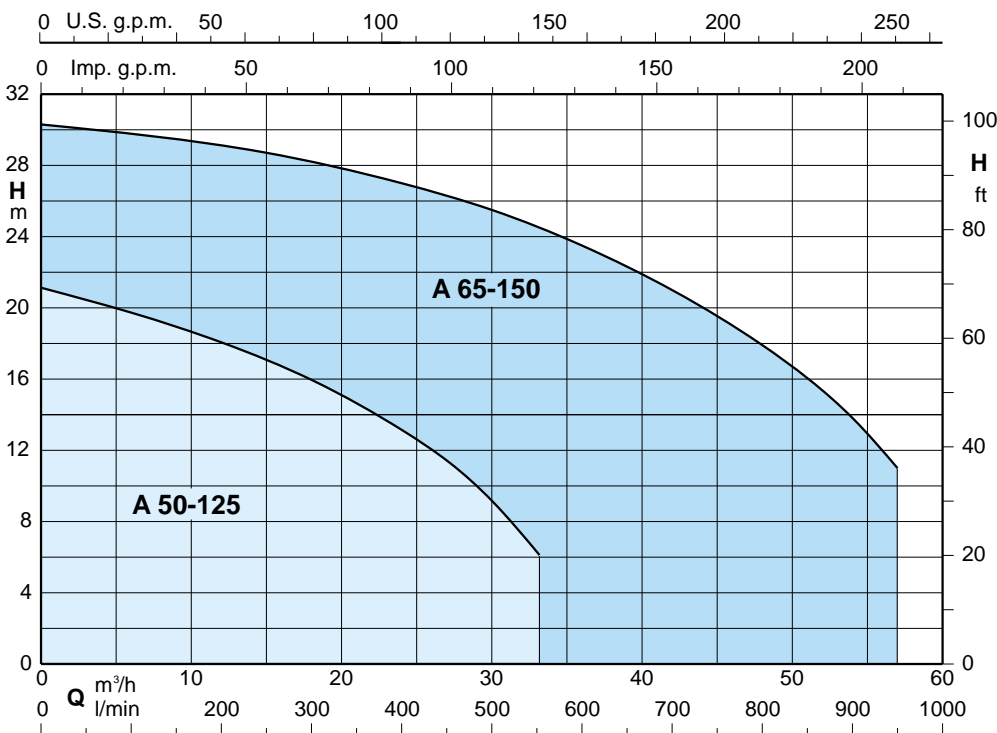



Performance $n \approx 2900$ rpm

3 ~	230 V 400 V		1 ~	230 V		P ₂		Q	H m										
	A	A		A	kW	kW	HP		m ³ /h	6	9	12	15	18	21	24	27	30	33
A 50-125CE B-A 50-125CE	4	2,3	AM 50-125CE B-AM 50-125CE	5,8	1,2	0,75	1	H m	100	150	200	250	300	350	400	450	500	550	
A 50-125BE B-A 50-125BE	5	2,9	AM 50-125BE B-AM 50-125BE	7,4	1,6	1,1	1,5		13	12,5	11,5	10,5	9,5	8	6	4			
A 50-125AE B-A 50-125AE	7,5	4,3	AM 50-125AE B-AM 50-125AE	9,2	2,1	1,5	2		16	15	14,5	13,5	12	10,5	9	7	5		
									19,5	19	18	17	16	14,5	13	11	9	6	

3 ~	230 V 400 V		P ₂		Q	H m											
	A	A	kW	HP		m ³ /h	15	18	24	30	33	36	42	48	54	57	
A 65-150CE B-A 65-150CE	9,15	5,3	2,2	3	H m	250	300	400	500	550	600	700	800	900	950		
A 65-150BE B-A 65-150BE	11	6,3	3	4		17,5	17	16	14	13	11,5	9	6,5				
A 65-150AE B-A 65-150AE	16,5	9,5	4	5,5		21,5	21	19,5	17,5	16,5	15,5	12,5	9,5	6,5			
						29	28	27	25,5	24,5	23,5	21	18	14	11		

P₁: Maximum power input.

B-A, B-AM = Bronze construction.

Tolerances according to ISO 9906, annex A.

P₂: Rated motor power output.

H Total head in m.

Dimensions and weights

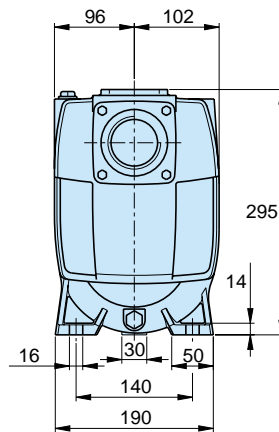
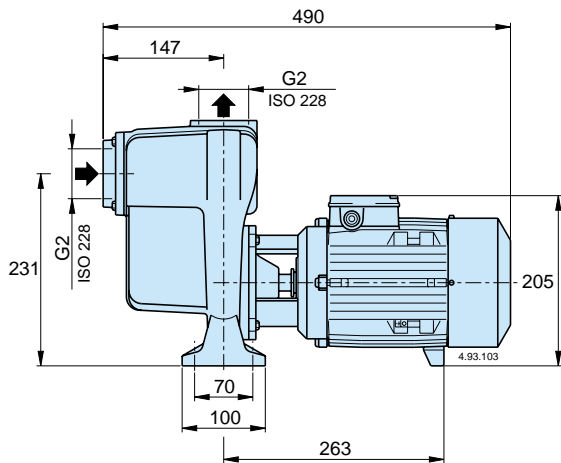

	kg
A 50-125AE	29,9
AM 50-125AE	31
A 50-125BE	28
AM 50-125BE	29,1
A 50-125CE	26,9
AM 50-125CE	27,8
B-A 50-125AE	33,6
B-AM 50-125AE	33,6
B-A 50-125BE	31
B-AM 50-125BE	32,6
B-A 50-125CE	29,6
B-AM 50-125CE	30,6

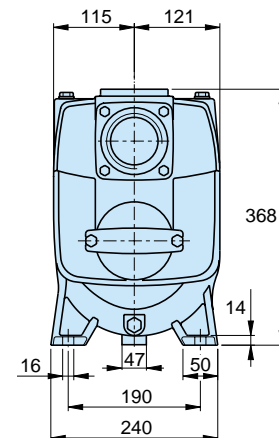
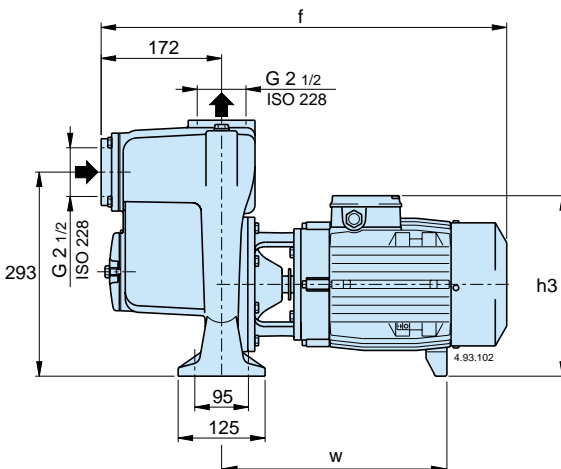

TYPE	mm			kg
	f	h3	w	
A 65-150CE B-A 65-150CE	561	242	292	46 47,5
A 65-150BE B-A 65-150BE	622	260	324	54 55,5
A 65-150AE B-A 65-150AE	622	260	324	58 59,5



Characteristic curves $n \approx 2900$ rpm

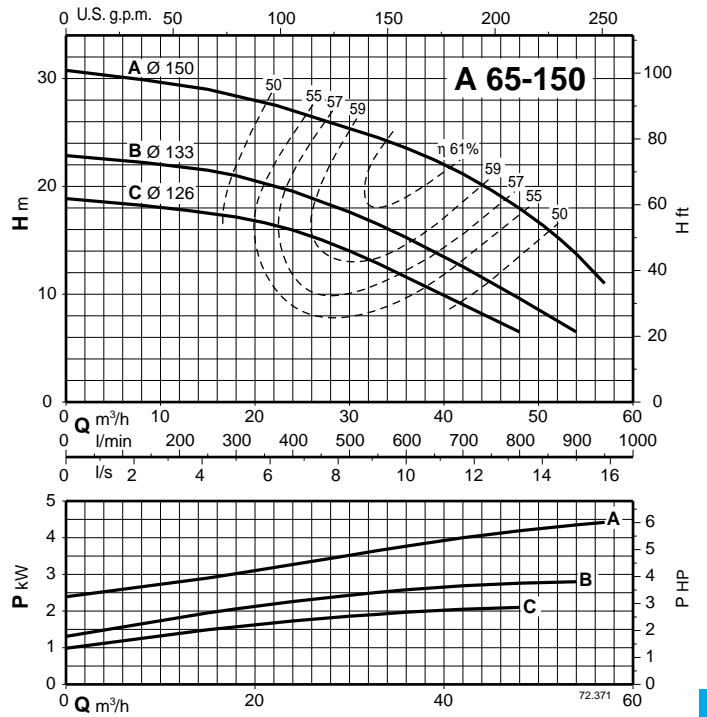
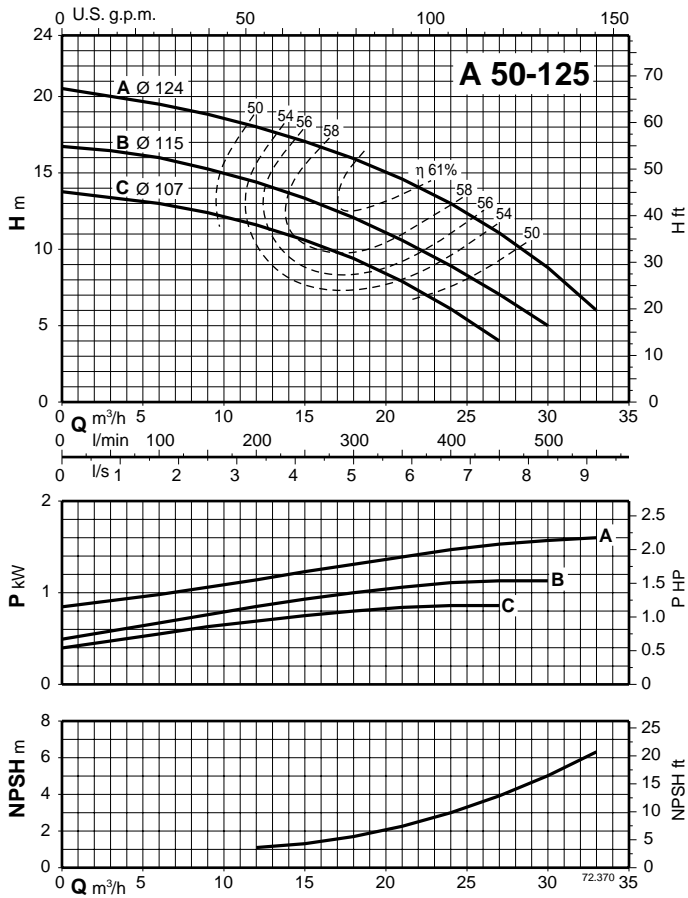



Self-priming Capability

A 50-125 with DN 50 mm suction pipe and cold water

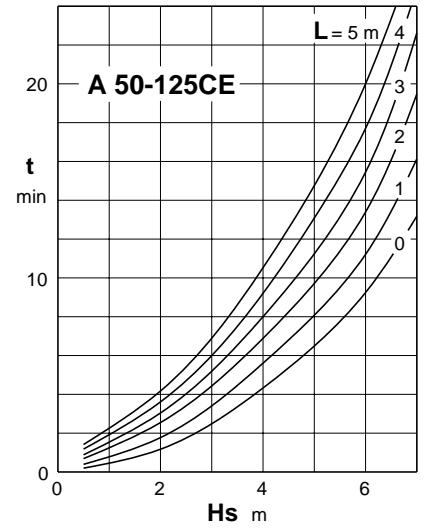
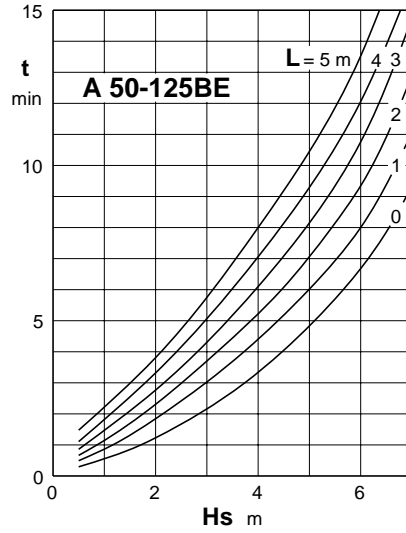
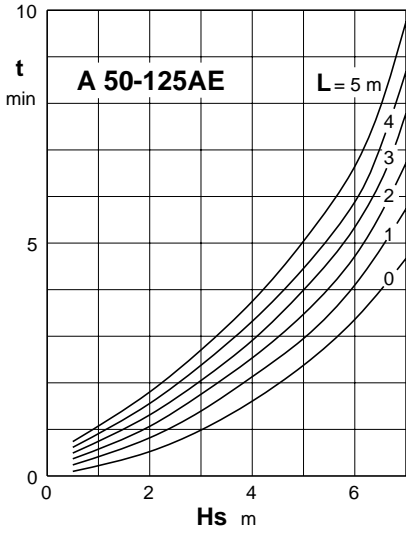

A 65-150 with DN 65 mm suction pipe and cold water

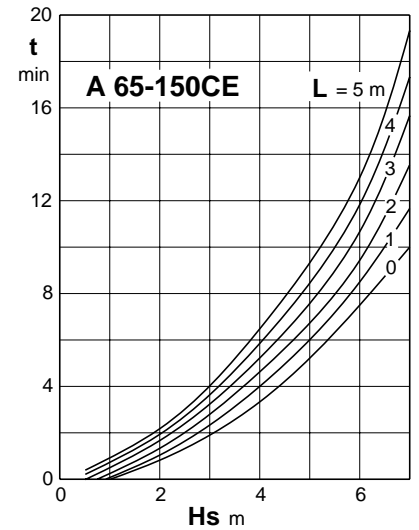
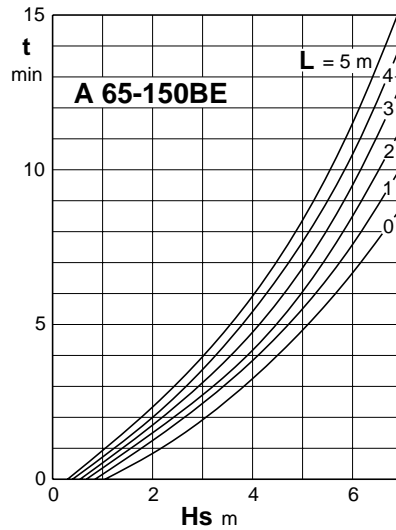
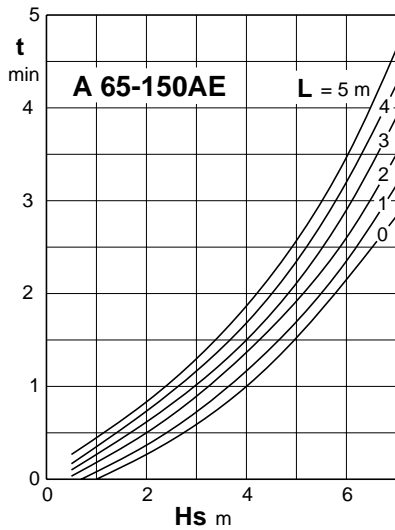

Hs (m) Suction lift.

L (m) Horizontal length of suction pipe above the water level.

t (min) Self-priming time.

