



Construction

Close-coupled gear pumps (rotary pumps).
Pump casing with suction and delivery connections with the same diameter and on the same axis (in-line execution).

Applications

For fuel oil and liquids with lubricating properties.

Operating conditions

Kinematic viscosity from 30 mm²/s (4°E) to 120 mm²/s (15°E).
Liquid temperature up to 90 °C.
Ambient temperature up to 40 °C.
Total suction lift up to 4 m.
Continuous duty.

Motor

4-pole induction motor, 50 Hz (n = 1450 rpm).

I 25/4E, IR 25/4E, IRR 25/4E: three-phase 230/400 V ± 10%.

IM 25/4E: single-phase 230 V ± 10%.

Insulation class F.

Protection IP 54.

Execution according to IEC 34.

Materials

Components	Materials
Pump casing	Cast iron GJL 200 EN 1561
Gears	Steel 18 Ni Cr Mo 5 UNI 8550
Shafts	Steel 18 Ni Cr Mo 5 UNI 8550
Radial shaft seal ring	Viton

Special features on request

- Other voltages.
- Frequency 60 Hz (as per 60 Hz data sheet).
- Protection IP 55.
- Higher ambient temperatures.

Performance $n \approx 1450$ 1/min

	3 ~ 230 V 400 V		1 ~ 230 V	P ₁	P ₂		n	Q	m ³ /h	0,6
	A	A			A	kW				
I 25/4E	1,4	0,8	IM25/4E	2,1	0,4	0,25	0,34	1450	Δp bar	2
IR 25/4E	2,1	1,2				0,37	0,5	1450		2,5
IRR 25/4E	3,5	2				0,75	1	1450		5

P₁ Max. power input.

P₂ Rated motor power output.

Δp Differential pressure.

Dimensions and weights

- I 25/4 E:** 10 kg
- IM 25/4 E:** 11,7 kg
- IR 25/4 E:** 11,6 kg

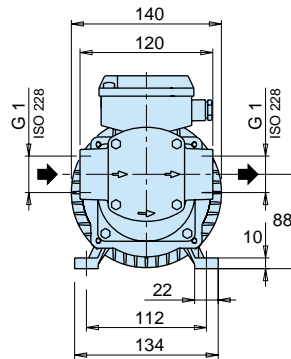
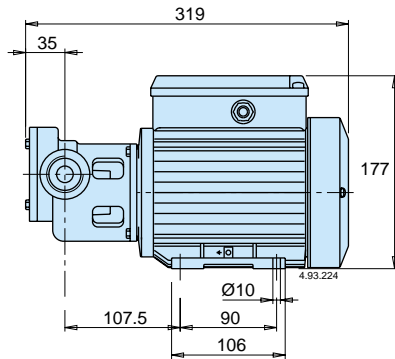

- IRR 25/4E:** 15,8 kg

