



Construction

Vertical multi-stage pumps with suction and delivery connections of the same diameter and arranged along the same axis (in-line). Corrosion-resistant bearing sleeves lubricated by the pumped liquid.

A pump with thrust bearing and sleeve coupling for use of any standard motor with V1 construction.

Applications

For water supply systems.

For clean non-explosive liquids, without solid, filamentary or abrasive matter (with adaptation of sealing materials on request).

A universal pump for civil and industrial use, for pressure-boosting systems, fire-extinguishing systems, high-pressure washing plants, irrigation, agricultural uses and sport installations.

Operating conditions

Temperature of liquid: from -15 °C to +110 °C.

Operating environment temperature: up to 40 °C.

Maximum permissible pressure in pump casing: 25 bar.

Motor

Standard-type: IM V1 (IEC 34-7) construction, insulation class F (IEC 85), degree of protection IP 55 (IEC 529); three-phase with rated voltage: up to 3 kW 230/400 V (IEC 38); from 4 kW 400/690 V (IEC 38).

Rated speed of rotation (50 Hz): **MXV** = 2900 rpm
MXV4 = 1450 rpm.

MXV 25-2, 32-4, 40-8

All parts that come into contact with the liquid, including wet-end covers, are in chrome-nickel stainless steel.

Materials (wetted parts)

Pos. Nr. (pag.86)	Component	Material
13.60	Flange	Chrome-nickel steel 1.4301 EN 10088 (AISI 304)
14.02	External jacket	
16.00	Suction casing	
20.00	Delivery casing	
25.02	Stage casing	
28.00	Impeller	
34.01	Lower cover	
34.02	Upper cover	
64.15	Spacer sleeve	
64.00	Pump shaft Plug	Chrome-nickel steel 1.4305 EN 10088 (AISI 303)
64.10	Bearing sleeve	Corrosion-resistant, cemented carbide Ceramic alumina
25.03	Bearing in stage casing	
36.00	Mechanical seal ISO 3069 - KU	Hard metal/Carbon/EPDM.
14.54	Wear ring	PTFE
	O-rings	NBR

Direction of rotation: clockwise as seen from the motor.

Variants (to be specified when ordering)

- Pump with threaded ports (G).
- Pump with flanged ports (F).
- Pump without motor.
- Pump with standard motor.

Other variants (on request)

- With counter-flanges in chrome-nickel steel.
- O-rings FPM (Viton).
- Other mechanical seal.
- Pump with motor of Client's choice (if available).
- Single-phase motor 230 V, up to 2.2 kW.
- Other voltage ratings. Frequency 60 Hz.

MXV 50-16, 65-32, 80-48

Internal parts in contact with the liquid in chrome-nickel stainless steel, with pump casing and upper cover in cast iron (in stainless steel on request).

Materials (wetted parts)

Pos. Nr. (pag.86)	Component	A (standard)	N
14.00	Pump casing	Cast iron GJL 250 EN 1561	Cr-Ni steel 1.4301 EN 10088 (AISI 304)
34.02	Upper cover		
14.02	External jacket	Chrome-nickel steel 1.4301 EN 10088 (AISI 304)	
25.02	Stage casing		
28.00	Impeller		
64.15	Spacer sleeve		
64.00	Pump shaft Plug	Chrome-nickel steel 1.4305 EN 10088 (AISI 303)	
64.10	Bearing sleeve	Corrosion-resistant, cemented carbide Ceramic alumina	
25.03	Bearing in stage casing		
36.00	Mechanical seal ISO 3069 - KU	Hard metal/Carbon/EPDM	
14.54	Wear ring	PTFE	
	O-rings	NBR	

Direction of rotation: anticlockwise as seen from the motor.

Variants (to be specified when ordering)

- Pump without motor.
- Pump with standard motor.

Other variants (on request)

- Pump with wetted ends in stainless steel (N).
- O-rings FPM (Viton).
- Other mechanical seal.
- Pump with motor of Client's choice (if available).
- Other voltage ratings. Frequency 60 Hz.
- Pump with support feet for horizontal installation (H1 or H2).
- Support feet for horizontal installation, set.
- Welding counter-flanges, PN 25 (steel).

MXV 25-2, 32-4, 40-8

Designation

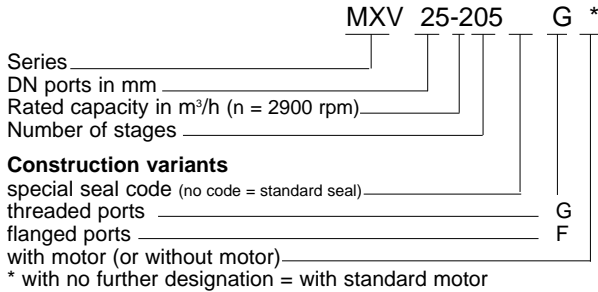

MXV 50-16, 65-32, 80-48

Designation

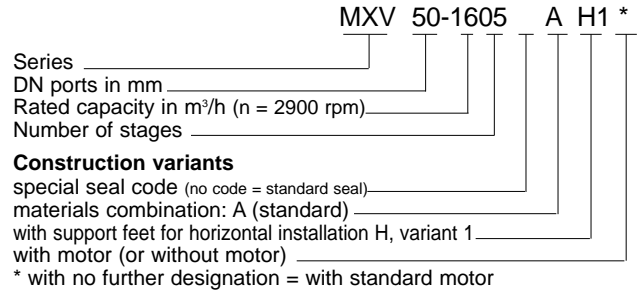

Pipe connection

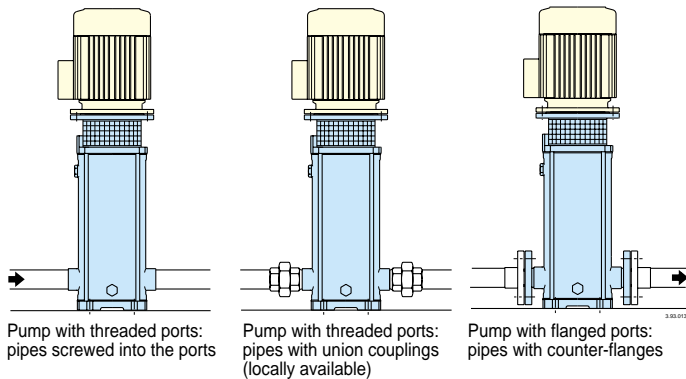

Installations

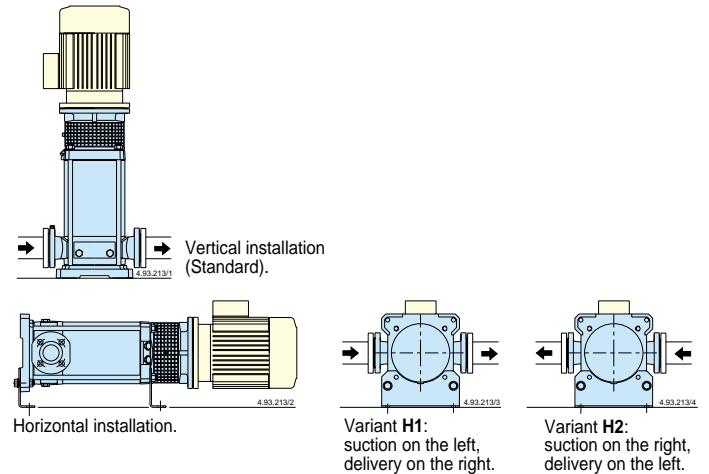

Variable parts

Pump size MXV - MXV4			Number of stages	Stage casings with bearing
25 - 204	32 - 404	40 - 804		
25 - 205	32 - 405	40 - 805	5	1
25 - 206	32 - 406	40 - 806	6	1
25 - 207	32 - 407	40 - 807	7	1
25 - 208	32 - 408	40 - 808	8	1
25 - 210	32 - 410		10	1
25 - 212	32 - 412	40 - 810	10	2
		40 - 811	11	2
		40 - 813	13	2
		40 - 815	15	2
25 - 214	32 - 414		14	2
25 - 216	32 - 416		16	2
25 - 218	32 - 418		18	2
25 - 220		40 - 817	17	3
		40 - 819	19	3
			20	3

Variable parts

Pump size MXV - MXV4			Number of stages	Stage casings with bearing
50 - 1603 50 - 1604 50 - 1605 50 - 1606 50 - 1607 50 - 1608 50 - 1609 50 - 1610	65 - 3202	80 - 4801		
	65 - 3203	80 - 4802	3	1
	65 - 3204	80 - 4803	4	1
	65 - 3205	80 - 4804	5	1
	65 - 3206	80 - 4805	6	1
	65 - 3207		7	1
			8	1
			9	1
			10	1
	50 - 1611 50 - 1612 50 - 1614 50 - 1616	65 - 3208	80 - 4806	6
65 - 3209		80 - 4807	7	2
65 - 3210		80 - 4808	8	2
			9	2
			10	2
65 - 3212			11	2
			12	2
			14	2
		16	2	

Coverage chart

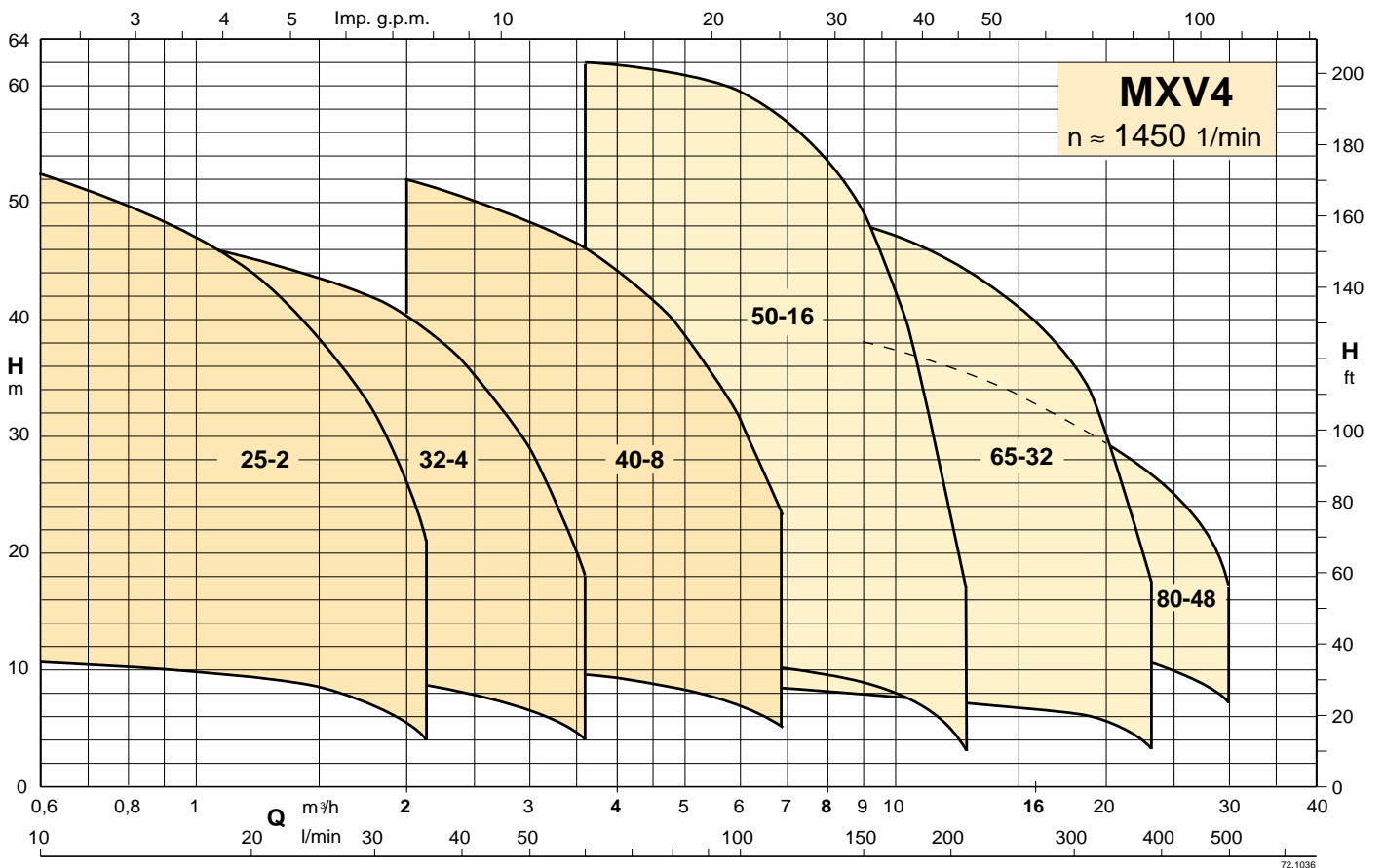
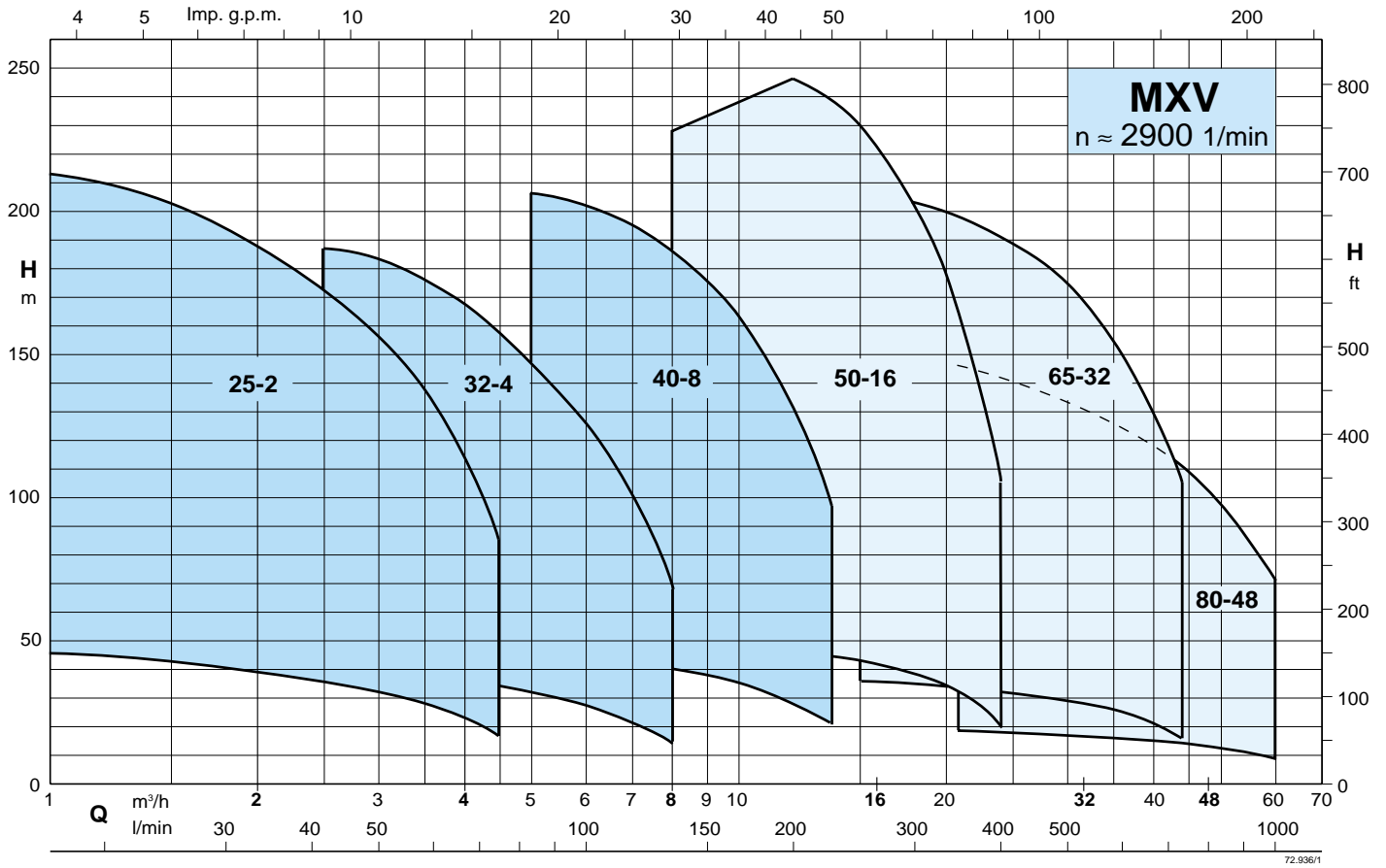

Characteristic curves and performance $n \approx 2900$ rpm

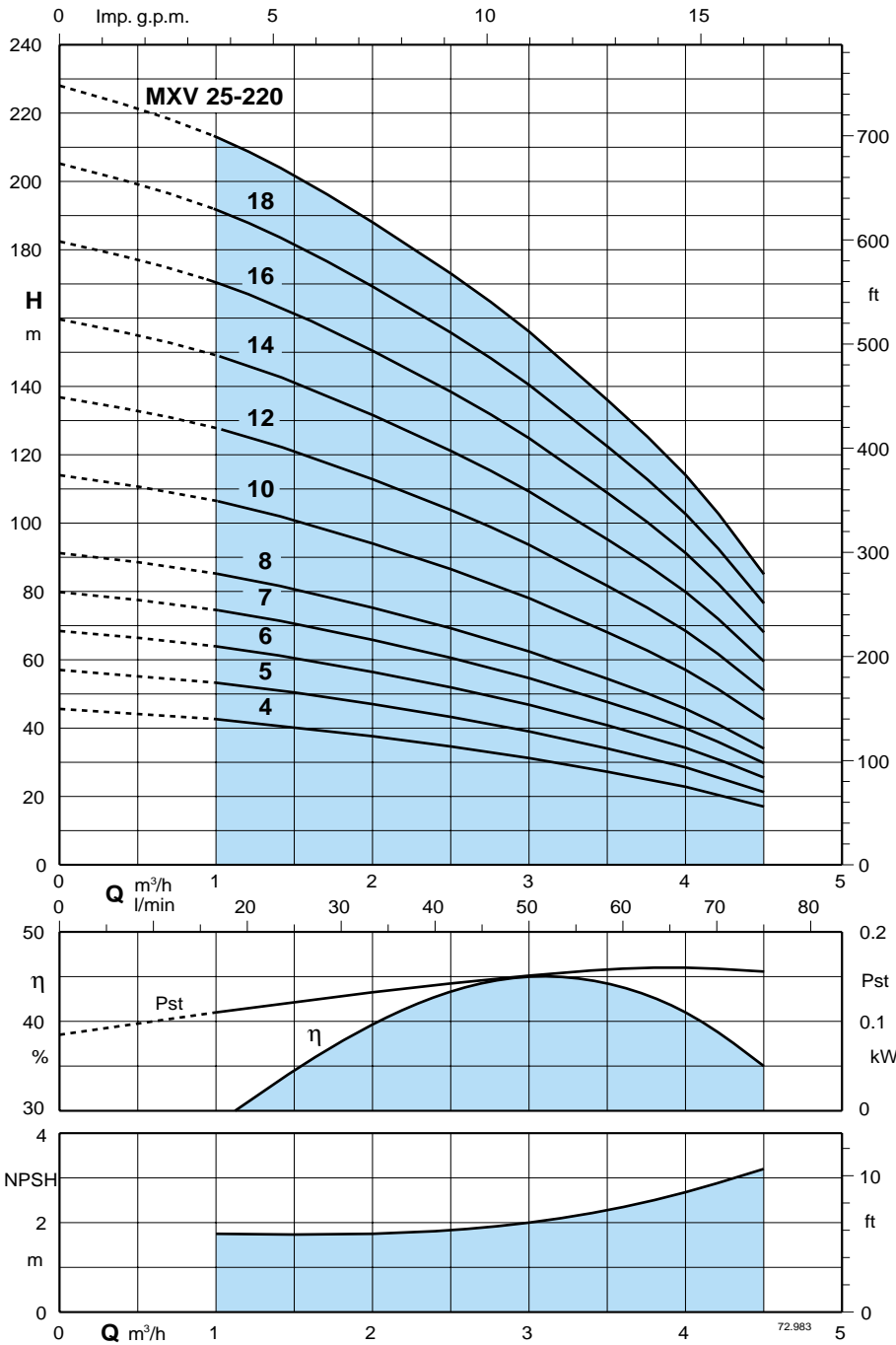

Test results with clean cold water, without gas content.

A safety margin of + 0.5 m is recommended for the NPSH value.

Tolerances in accordance with ISO 9906, Annex A.

Head and power values valid for liquids with density $\rho = 1,0 \text{ kg/dm}^3$ and kinematic viscosity $\nu = \text{max } 20 \text{ mm}^2/\text{sec}$.

Pst = Power with reference to one stage.

Pump type	Motor power		Q m³/h l/min	0	1	1,5	2	2,5	3	3,5	4	4,5
	kW	HP		0	16,6	25	33,3	41,6	50	58,3	66,6	75
MXV 25 - 204	0,75	1	H m	44	42,5	40	37,5	34,5	31	27	22,5	17
MXV 25 - 205	0,75	1		56	53	50	47	43	39	34	28	21
MXV 25 - 206	1,1	1,5		68	63,5	60,5	56	51,5	46,5	40,5	34	25
MXV 25 - 207	1,1	1,5		79,5	74	70,5	65,5	60	54,5	47,5	39,5	30
MXV 25 - 208	1,5	2		91	85	80,5	75	69	62	54	45,5	34
MXV 25 - 210	1,5	2		114	106	101	94	86	78	68	57	42
MXV 25 - 212	2,2	3		136	127	121	112	103	93,5	81,5	68	51
MXV 25 - 214	2,2	3		159	149	141	131	121	109	95	79,5	59
MXV 25 - 216	3	4		182	170	161	150	138	124	108	91	68
MXV 25 - 218	3	4		205	191	181	169	155	140	122	102	76
MXV 25 - 220	3	4		228	213	202	188	173	156	136	114	85

Characteristic curves and performance $n \approx 2900$ rpm

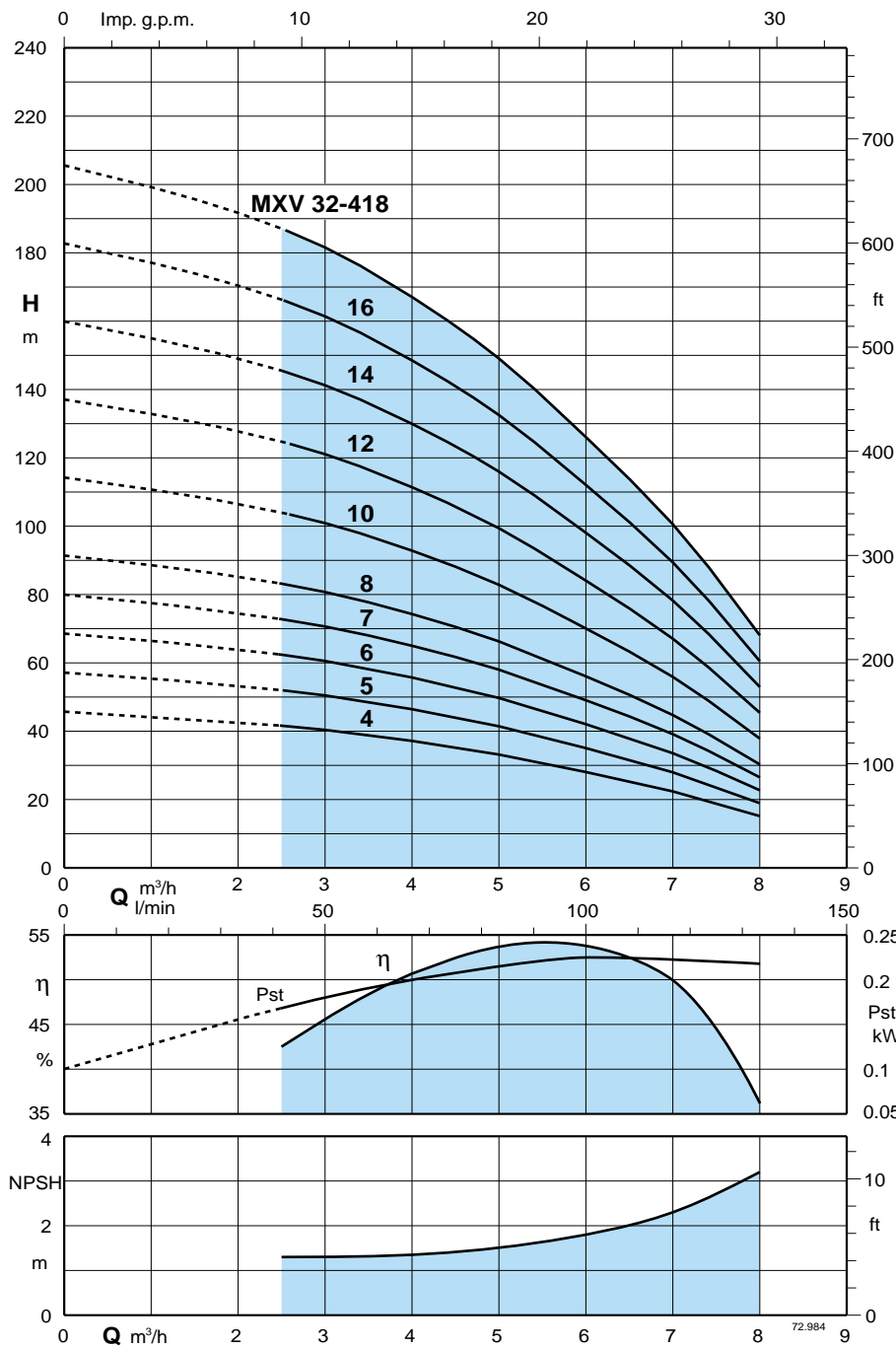

Test results with clean cold water, without gas content.

A safety margin of + 0.5 m is recommended for the NPSH value.

Tolerances in accordance with ISO 9906, Annex A.

Head and power values valid for liquids with density $\rho = 1,0 \text{ kg/dm}^3$ and kinematic viscosity $\nu = \text{max } 20 \text{ mm}^2/\text{sec}$.

Pst = Power with reference to one stage.

Pump type	Motor power		Q m³/h l/min	H m											
	kW	HP		0	2,5	3	3,5	4	4,5	5	6	7	8		
MXV 32 - 404	1,1	1,5	0	0	41,6	50	58,3	66,6	75	83,3	100	116,6	133,3		
MXV 32 - 405	1,1	1,5	45	41,5	40	38,5	36,5	34,5	32,5	27,5	22	14,5			
MXV 32 - 406	1,5	2	56	51,5	50	48	46	43,5	41	34,5	27,5	18,5			
MXV 32 - 407	1,5	2	68	62	60	58	55,5	52,5	49,5	42	33,5	22,5			
MXV 32 - 408	2,2	3	79,5	72,5	70,5	68	65	61,5	58	49	39	26,5			
MXV 32 - 410	2,2	3	91	83	80,5	78	74	70	66	56	44,5	30			
MXV 32 - 412	3	4	114	104	101	97,5	93	88	83	70	56	38			
MXV 32 - 414	3	4	136	124	121	117	111	105	99,5	84	67	45,5			
MXV 32 - 416	4	5,5	159	145	141	136	130	123	116	98	78	53			
MXV 32 - 418	4	5,5	182	166	161	156	148	140	132	112	89,5	60,5			
			205	187	181	175	167	158	149	126	100	68			

Characteristic curves and performance $n \approx 2900$ rpm

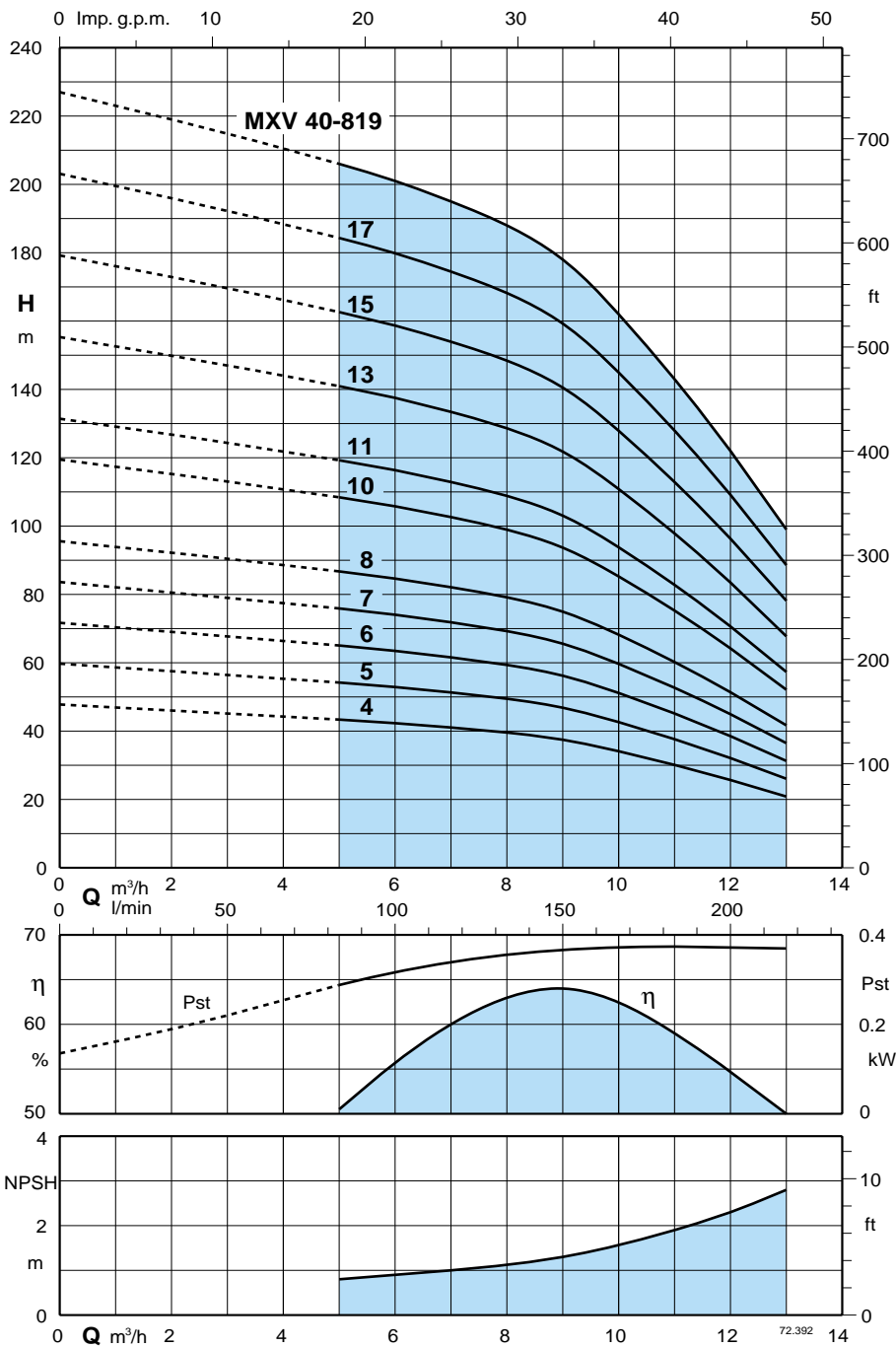

Test results with clean cold water, without gas content.

A safety margin of + 0.5 m is recommended for the NPSH value.

Tolerances in accordance with ISO 9906, Annex A.

Head and power values valid for liquids with density $\rho = 1,0 \text{ kg/dm}^3$ and kinematic viscosity $\nu = \text{max } 20 \text{ mm}^2/\text{sec}$.

Pst = Power with reference to one stage.

Pump type	Motor power		Q m³/h l/min	0	5	6	7	8	9	10	11	12	13
	kW	HP		0	83,3	100	116,6	133,3	150	166,6	183,3	200	216,6
MXV 40 - 804	1,5	2	H m	47	43	42	41	40	37	34	30	26	21
MXV 40 - 805	2,2	3		59	54	53	51	50	47	43	38	32	26
MXV 40 - 806	2,2	3		71	65	63	62	59	56	51	45	39	31
MXV 40 - 807	3	4		83	76	74	72	69	66	60	53	45	36
MXV 40 - 808	3	4		95	87	85	82	79	75	69	60	51	42
MXV 40 - 810	4	5,5		119	109	106	103	99	94	86	75	64	52
MXV 40 - 811	4	5,5		131	119	116	113	109	103	94	83	71	57
MXV 40 - 813	5,5	7,5		155	141	138	134	129	122	111	98	84	68
MXV 40 - 815	5,5	7,5		179	163	159	154	149	141	128	113	96	78
MXV 40 - 817	7,5	10		202	184	180	175	168	159	145	128	109	89
MXV 40 - 819	7,5	10		226	206	201	195	188	178	162	143	122	99

Characteristic curves and performance $n \approx 2900$ rpm

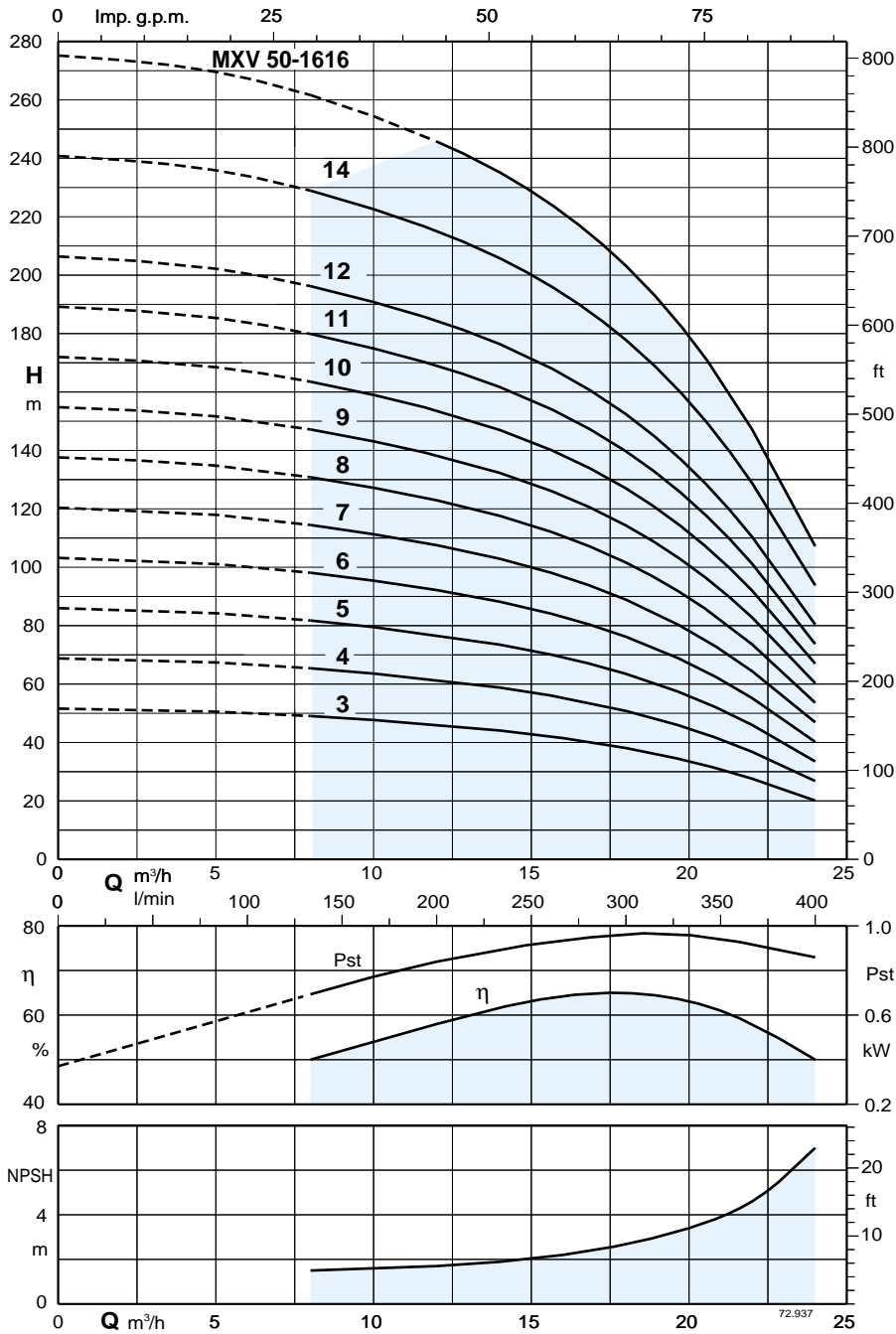

Test results with clean cold water, without gas content.

A safety margin of + 0.5 m is recommended for the NPSH value.

Tolerances in accordance with ISO 9906, Annex A.

Head and power values valid for liquids with density $\rho = 1,0 \text{ kg/dm}^3$ and kinematic viscosity $\nu = \text{max } 20 \text{ mm}^2/\text{sec}$.

Pst = Power with reference to one stage.

Pump type	Motor power		Q m³/h l/min	H m																		
	kW	HP		0	8	10	12	14	16	18	20	22	24									
MXV 50 - 1603	3	4	0	133,3	166,6	200	233	266	300	333	366	400	51	49	48	46	44	41	38	33	27	20
MXV 50 - 1604	4	5,5	0	133,3	166,6	200	233	266	300	333	366	400	69	65	63	61	59	55	51	44	37	27
MXV 50 - 1605	5,5	7,5	0	133,3	166,6	200	233	266	300	333	366	400	86	81	79	76	73	69	63	55	46	33
MXV 50 - 1606	5,5	7,5	0	133,3	166,6	200	233	266	300	333	366	400	103	98	95	92	88	83	76	67	55	40
MXV 50 - 1607	7,5	10	0	133,3	166,6	200	233	266	300	333	366	400	120	114	111	107	103	97	89	78	64	47
MXV 50 - 1608	7,5	10	0	133,3	166,6	200	233	266	300	333	366	400	138	130	127	122	117	110	101	89	73	53
MXV 50 - 1609	11	15	0	133,3	166,6	200	233	266	300	333	366	400	155	147	143	138	132	124	114	100	83	60
MXV 50 - 1610	11	15	0	133,3	166,6	200	233	266	300	333	366	400	172	163	159	153	147	138	127	111	92	67
MXV 50 - 1611	11	15	0	133,3	166,6	200	233	266	300	333	366	400	189	179	175	168	161	152	139	122	101	73
MXV 50 - 1612	15	20	0	133,3	166,6	200	233	266	300	333	366	400	206	196	190	184	176	166	152	133	110	80
MXV 50 - 1614	15	20	0	133,3	166,6	200	233	266	300	333	366	400	240	228	222	214	206	193	178	156	129	94
MXV 50 - 1616	18,5	25	0	133,3	166,6	200	233	266	300	333	366	400	275			245	235	221	203	178	147	107

Characteristic curves and performance $n \approx 2900$ rpm

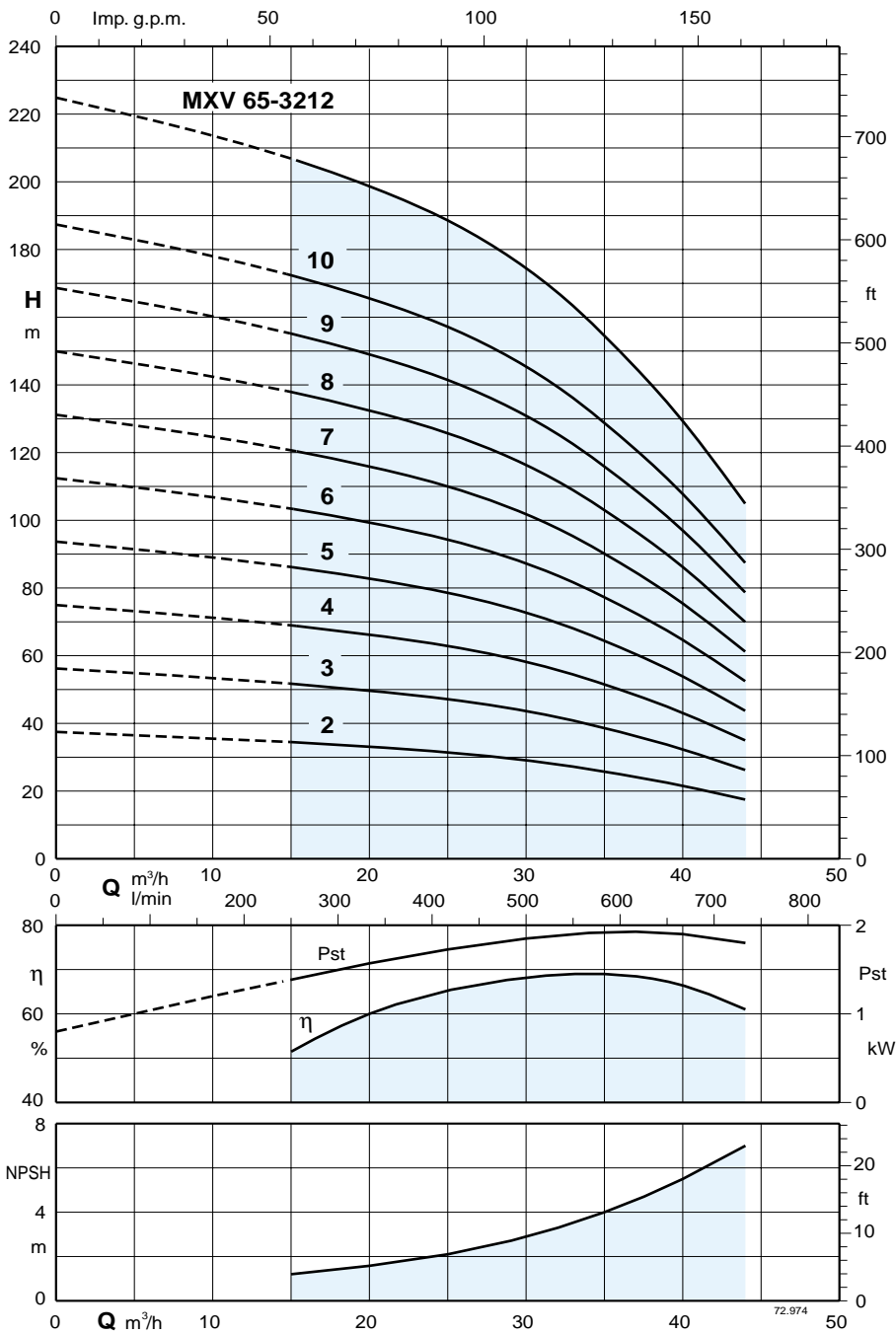

Test results with clean cold water, without gas content.

A safety margin of + 0.5 m is recommended for the NPSH value.

Tolerances in accordance with ISO 9906, Annex A.

Head and power values valid for liquids with density $\rho = 1,0 \text{ kg/dm}^3$ and kinematic viscosity $\nu = \text{max } 20 \text{ mm}^2/\text{sec}$.

Pst = Power with reference to one stage.

Pump type	Motor power		Q m³/h l/min	H m																		
	kW	HP		0	15	21	24	27	30	33	36	39	44									
MXV 65 - 3202	4	5,5	0	250	350	400	450	500	550	600	650	733	37	34	32	31	30	29	27	24,5	22	17
MXV 65 - 3203	5,5	7,5	0	250	350	400	450	500	550	600	650	733	55,5	51	49	47,5	46	43,5	40,5	37	33,5	25,5
MXV 65 - 3204	7,5	10	0	250	350	400	450	500	550	600	650	733	75	69	65,5	63,5	61	58,5	54,5	50	45	35
MXV 65 - 3205	11	15	0	250	350	400	450	500	550	600	650	733	93,5	86	82	79,5	77	73	68	62,5	56,5	44
MXV 65 - 3206	11	15	0	250	350	400	450	500	550	600	650	733	112	103	98,5	95,5	92	87	82	75	67,5	52,5
MXV 65 - 3207	15	20	0	250	350	400	450	500	550	600	650	733	131	121	115	111	107	102	95,5	87,5	79	61,5
MXV 65 - 3208	15	20	0	250	350	400	450	500	550	600	650	733	150	138	131	127	123	116	109	100	90	70
MXV 65 - 3209	18,5	25	0	250	350	400	450	500	550	600	650	733	168	155	148	143	138	130	122	112	101	79
MXV 65 - 3210	18,5	25	0	250	350	400	450	500	550	600	650	733	187	172	164	159	154	145	136	125	112	87,5
MXV 65 - 3212	22	30	0	250	350	400	450	500	550	600	650	733	225	207	197	191	185	174	163	150	135	105

Characteristic curves and performance $n \approx 2900$ rpm

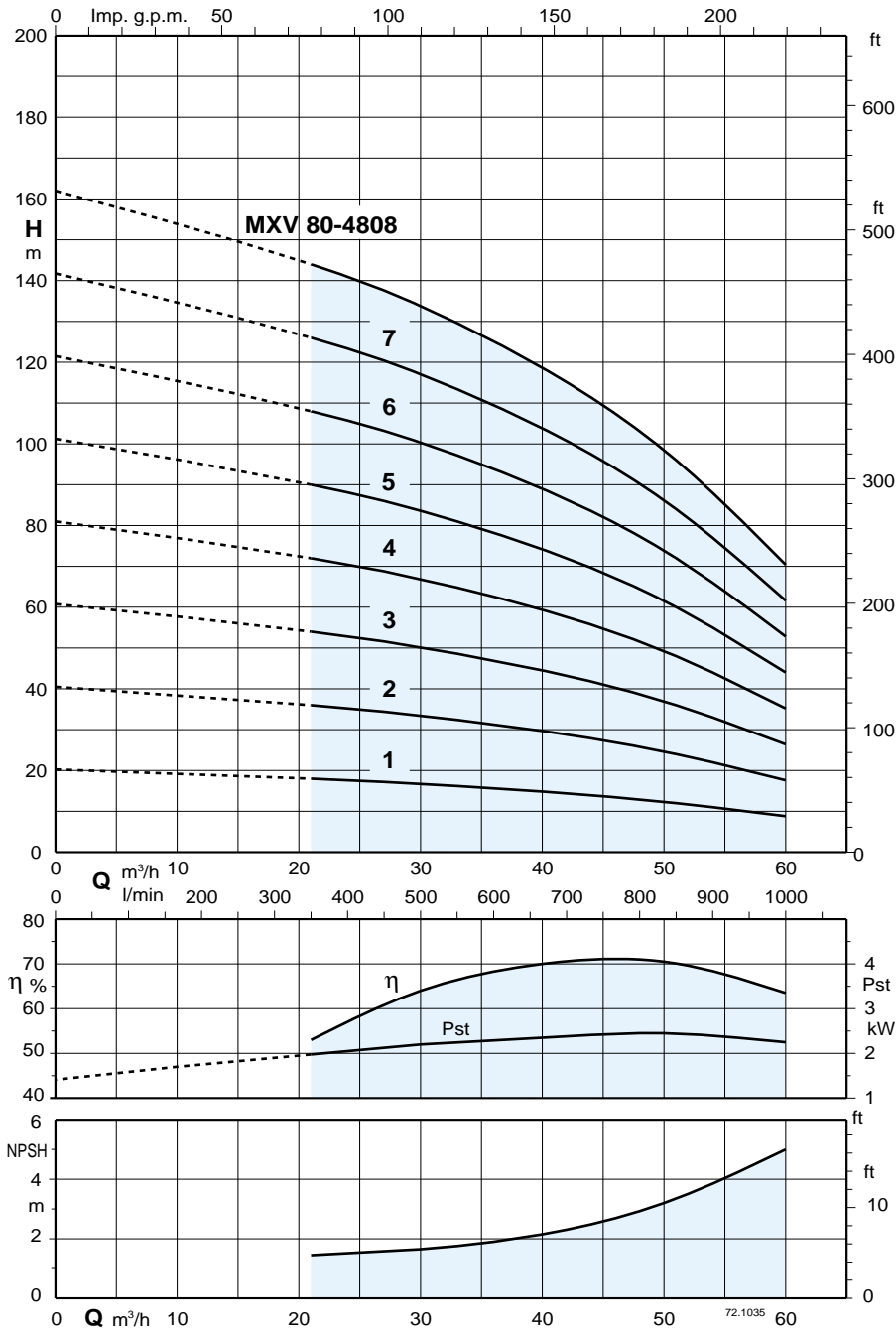

Test results with clean cold water, without gas content.

A safety margin of + 0.5 m is recommended for the NPSH value.

Tolerances in accordance with ISO 9906, Annex A.

Head and power values valid for liquids with density $\rho = 1,0 \text{ kg/dm}^3$ and kinematic viscosity $\nu = \text{max } 20 \text{ mm}^2/\text{sec}$.

Pst = Power with reference to one stage.

Pump type	Motor power		Q m³/h l/min	Head (H) in meters										
	kW	HP		0	21	27	33	39	45	48	51	54	60	
MXV 80 - 4801	4	5,5	0	18	17	16	15	13,5	13	12	11	9		
MXV 80 - 4802	5,5	7,5	0	350	450	550	650	750	800	850	900	1000		
MXV 80 - 4803	7,5	10	20	18	17	16	15	13,5	13	12	11	9		
MXV 80 - 4804	11	15	40,5	36	34,5	32,5	30	27,5	26	24	22	17,5		
MXV 80 - 4805	15	20	61	54	51,5	48,5	45	41	39	36	33	26,5		
MXV 80 - 4806	15	20	81	72	69	65	60	55	51,5	48	44	35		
MXV 80 - 4807	18,5	25	101	90	86	81	75	68,5	64,5	60	55	44		
MXV 80 - 4808	22	30	121	108	103	97	90	82	77,5	72	66	53		
			142	126	120	113	105	96	90	84	77	61,5		
			162	144	137	129	120	109	103	96	88	70,5		

Dimensions and weights

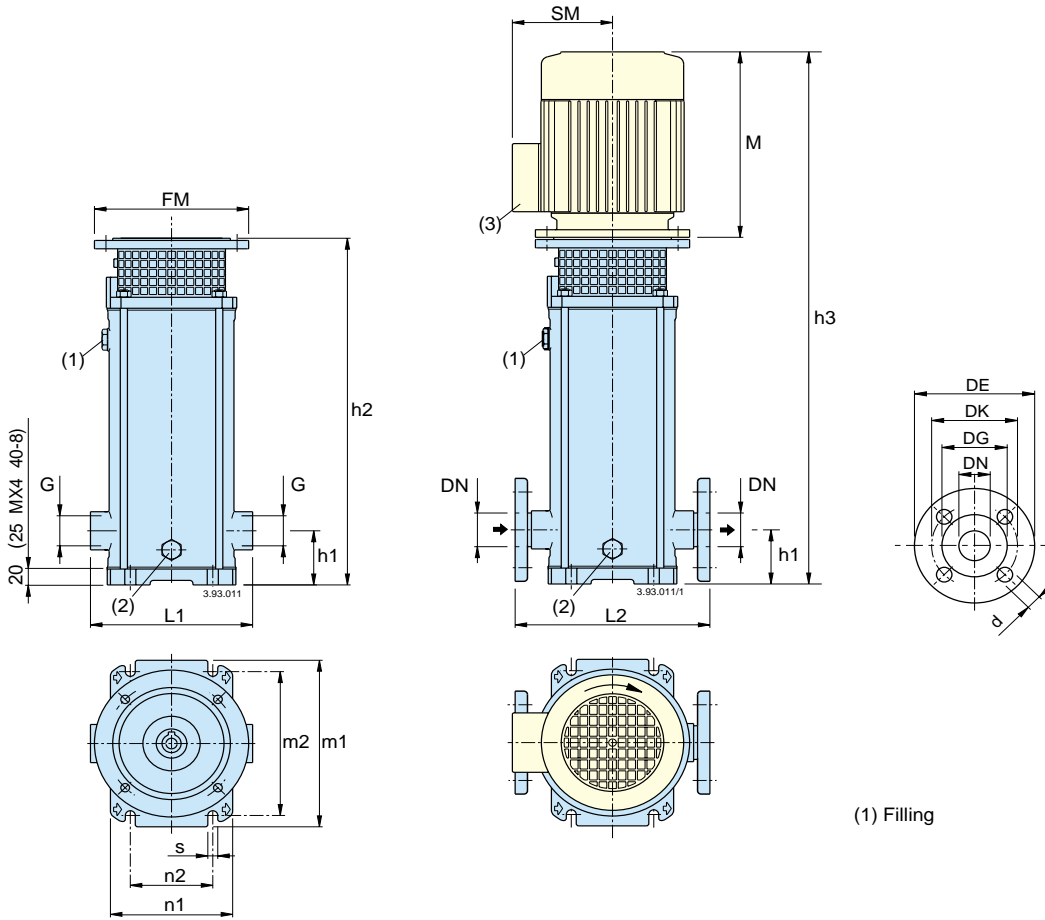

Counterflanges in stainless steel

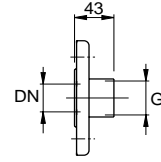

DN	G ISO 228
25	1
32	1 1/4
40	1 1/2

Flanges ISO 7005 PN 25 - 40

DN	DE	DK	DG	Holes	
				N.	Ø
25	115	85	65	4	14
32	140	100	76	4	18
40	150	110	86	4	18

Pump	Motor			MXV (G) threaded ports	MXV (F) flanged ports	mm													without motor	with motor
	kW	HP				G ISO 228	L1	DN	L2	h1	h2	(5) M	h3	FM	(5) SM	m1	m2	n1	n2	s
MXV 25-204	0,75	1	80A	G1	215	25	250	75	372	234	606	200	120	210	180	150	100	12,5	18	27
MXV 25-205	0,75	1	80A	G1	215	25	250	75	396	234	630	200	120	210	180	150	100	12,5	19	28
MXV 25-206	1,1	1,5	80B	G1	215	25	250	75	420	234	654	200	120	210	180	150	100	12,5	20	30
MXV 25-207	1,1	1,5	80B	G1	215	25	250	75	444	234	678	200	120	210	180	150	100	12,5	21	31
MXV 25-208	1,5	2	90 S	G1	215	25	250	75	478	282	760	200	128	210	180	150	100	12,5	22	35
MXV 25-210	1,5	2	90 S	G1	215	25	250	75	526	282	808	200	128	210	180	150	100	12,5	23	36
MXV 25-212	2,2	3	90 L	G1	215	25	250	75	574	282	856	200	128	210	180	150	100	12,5	25	41
MXV 25-214	2,2	3	90 L	G1	215	25	250	75	622	282	904	200	128	210	180	150	100	12,5	26	42
MXV 25-216	3	4	100 L	G1	215	25	250	75	680	313	993	250	135	210	180	150	100	12,5	29	52
MXV 25-218	3	4	100 L	G1	215	25	250	75	728	313	1041	250	135	210	180	150	100	12,5	31	54
MXV 25-220	3	4	100 L	G1	215	25	250	75	776	313	1089	250	135	210	180	150	100	12,5	32	55
MXV 32-404	1,1	1,5	80 B	G1 1/4	215	32	250	75	372	234	606	200	120	210	180	150	100	12,5	19	29
MXV 32-405	1,1	1,5	80 B	G1 1/4	215	32	250	75	396	234	630	200	120	210	180	150	100	12,5	20	30
MXV 32-406	1,5	2	90 S	G1 1/4	215	32	250	75	430	282	712	200	128	210	180	150	100	12,5	21	34
MXV 32-407	1,5	2	90 S	G1 1/4	215	32	250	75	454	282	736	200	128	210	180	150	100	12,5	22	35
MXV 32-408	2,2	3	90 L	G1 1/4	215	32	250	75	478	282	760	200	128	210	180	150	100	12,5	23	39
MXV 32-410	2,2	3	90 L	G1 1/4	215	32	250	75	526	282	808	200	128	210	180	150	100	12,5	24	40
MXV 32-412	3	4	100 L	G1 1/4	215	32	250	75	584	313	897	250	135	210	180	150	100	12,5	27	50
MXV 32-414	3	4	100 L	G1 1/4	215	32	250	75	632	313	945	250	135	210	180	150	100	12,5	29	52
MXV 32-416	4	5,5	112 M	G1 1/4	215	32	250	75	680	334	1014	250	148	210	180	150	100	12,5	30	60
MXV 32-418	4	5,5	112 M	G1 1/4	215	32	250	75	728	334	1062	250	148	210	180	150	100	12,5	31	61
MXV 40-804	1,5	2	90 S	G1 1/2	225	40	280	80	411	282	693	200	128	246	215	190	130	14	21	34
MXV 40-805	2,2	3	90 L	G1 1/2	225	40	280	80	441	282	723	200	128	246	215	190	130	14	22	38
MXV 40-806	2,2	3	90 L	G1 1/2	225	40	280	80	471	282	753	200	128	246	215	190	130	14	23	39
MXV 40-807	3	4	100 L	G1 1/2	225	40	280	80	511	313	824	250	135	246	215	190	130	14	25	48
MXV 40-808	3	4	100 L	G1 1/2	225	40	280	80	541	313	854	250	135	246	215	190	130	14	26	49
MXV 40-810	4	5,5	112 M	G1 1/2	225	40	280	80	601	334	935	250	148	246	215	190	130	14	28	58
MXV 40-811	4	5,5	112 M	G1 1/2	225	40	280	80	631	334	965	250	148	246	215	190	130	14	29	59
MXV 40-813	5,5	7,5	132 SA	G1 1/2	225	40	280	80	711	374	1085	300	167	246	215	190	130	14	35	78
MXV 40-815	5,5	7,5	132 SA	G1 1/2	225	40	280	80	771	374	1145	300	167	246	215	190	130	14	36	79
MXV 40-817	7,5	10	132 SB	G1 1/2	225	40	280	80	831	374	1205	300	167	246	215	190	130	14	38	91
MXV 40-819	7,5	10	132 SB	G1 1/2	225	40	280	80	891	374	1265	300	167	246	215	190	130	14	39	92

(3) Standard position of terminal box. (for other positions rotate motor through 90° or 180°)

(4) MXV (F) = MXV (G) + 1kg

(5) With standard motor

(6) Net weight

Dimensions and weights

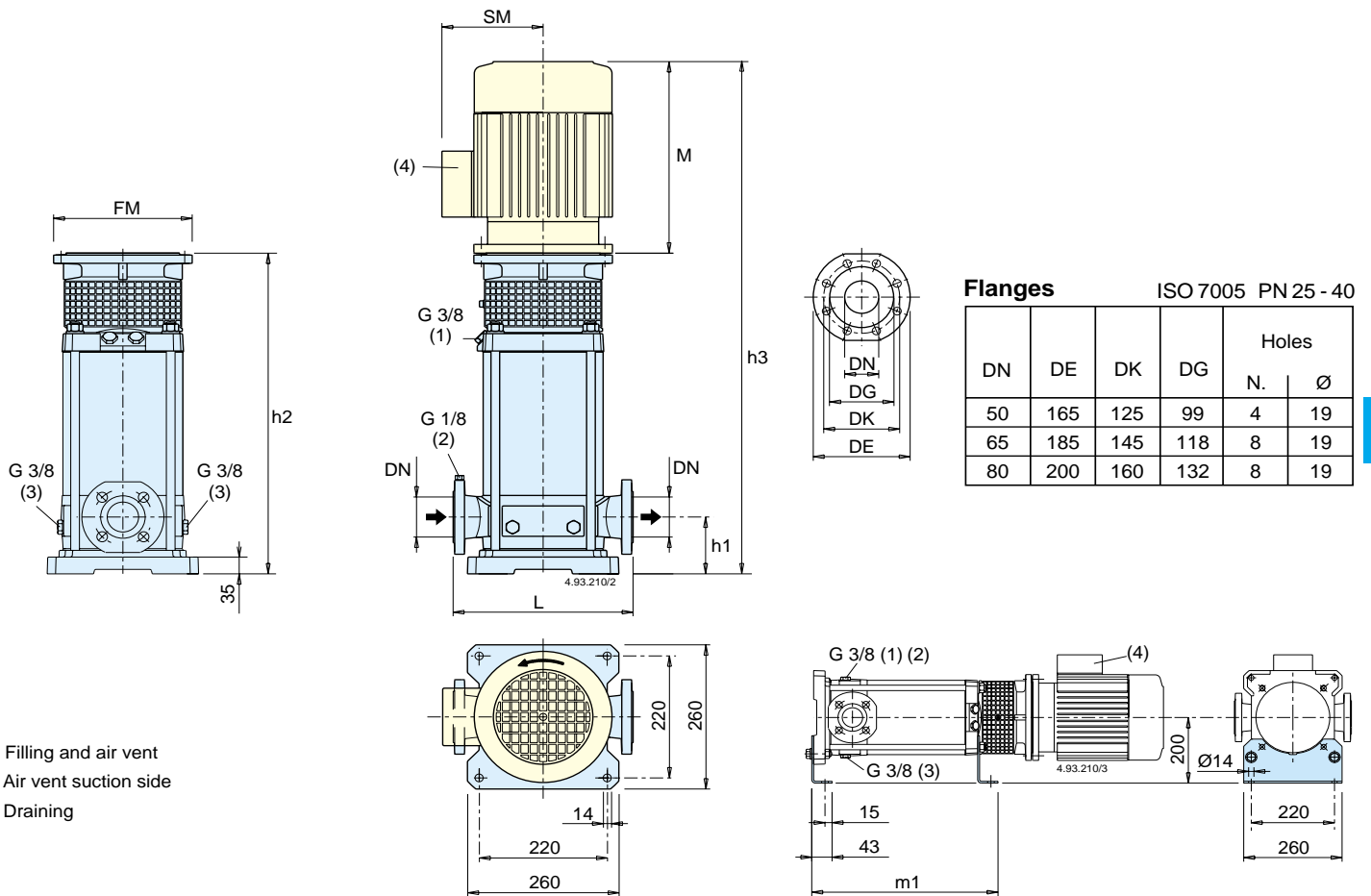

- (1) Filling and air vent
- (2) Air vent suction side
- (3) Draining

Pump	Motor			mm									without motor	with motor
				DN	L	h1	h2	(6) M	h3	FM	(6) SM	m1	MXV (A) (5) kg (7)	(6) kg (7)
MXV 50-1603	3	4	100 L	50	300	90	395	313	708	250	135	322	42	65
MXV 50-1604	4	5,5	112M	50	300	90	430	334	764	250	148	357	43	73
MXV 50-1605	5,5	7,5	132SA	50	300	90	484	374	858	300	167	391	49	92
MXV 50-1606	5,5	7,5	132SA	50	300	90	519	374	893	300	167	426	51	94
MXV 50-1607	7,5	10	132SB	50	300	90	553	374	927	300	167	460	52	105
MXV 50-1608	7,5	10	132SB	50	300	90	588	374	962	300	167	495	53	106
MXV 50-1609	11	15	160MA	50	300	90	652	478	1130	350	197	529	62	134
MXV 50-1610	11	15	160MA	50	300	90	687	478	1165	350	197	564	64	136
MXV 50-1611	11	15	160MA	50	300	90	721	478	1199	350	197	598	65	137
MXV 50-1612	15	20	160MB	50	300	90	756	478	1234	350	197	633	67	152
MXV 50-1614	15	20	160MB	50	300	90	825	478	1303	350	197	702	70	155
MXV 50-1616	18,5	25	160L	50	300	90	894	478	1372	350	197	771	73	175
MXV 65-3202	4	5,5	112 M	65	320	105	407	334	741	250	148	334	45	75
MXV 65-3203	5,5	7,5	132SA	65	320	105	473	374	847	300	167	380	51	94
MXV 65-3204	7,5	10	132SB	65	320	105	519	374	893	300	167	426	53	106
MXV 65-3205	11	15	160MA	65	320	105	595	478	1073	350	197	472	62	134
MXV 65-3206	11	15	160MA	65	320	105	641	478	1119	350	197	518	64	136
MXV 65-3207	15	20	160MB	65	320	105	687	478	1165	350	197	564	66	151
MXV 65-3208	15	20	160MB	65	320	105	733	478	1211	350	197	610	68	153
MXV 65-3209	18,5	25	160L	65	320	105	779	478	1257	350	197	656	70	172
MXV 65-3210	18,5	25	160L	65	320	105	825	478	1303	350	197	702	72	174
MXV 65-3212	22	30	180M	65	320	105	917	602	1519	350	259	794	75	190
MXV 80-4801	4	5,5	112 M	80	320	105	411	334	745	250	148	338	45	75
MXV 80-4802	5,5	7,5	132SA	80	320	105	466	374	840	300	167	373	51	94
MXV 80-4803	7,5	10	132SB	80	320	105	527	374	901	300	167	434	54	107
MXV 80-4804	11	15	160MA	80	320	105	618	478	1096	350	197	495	64	136
MXV 80-4805	15	20	160MB	80	320	105	680	478	1158	350	197	557	66	151
MXV 80-4806	15	20	160MB	80	320	105	741	478	1219	350	197	618	69	154
MXV 80-4807	18,5	25	160L	80	320	105	802	478	1280	350	197	679	72	174
MXV 80-4808	22	30	180M	80	320	105	864	602	1466	350	259	741	74	189

(4) Standard position of terminal box. (for other positions rotate motor through 90° or 180°)

(5) MXV (N) : + 3 kg
MXV (H) : + 3 kg

(6) With standard motor

(7) Net weight

Characteristic curves and performance $n \approx 1450$ rpm

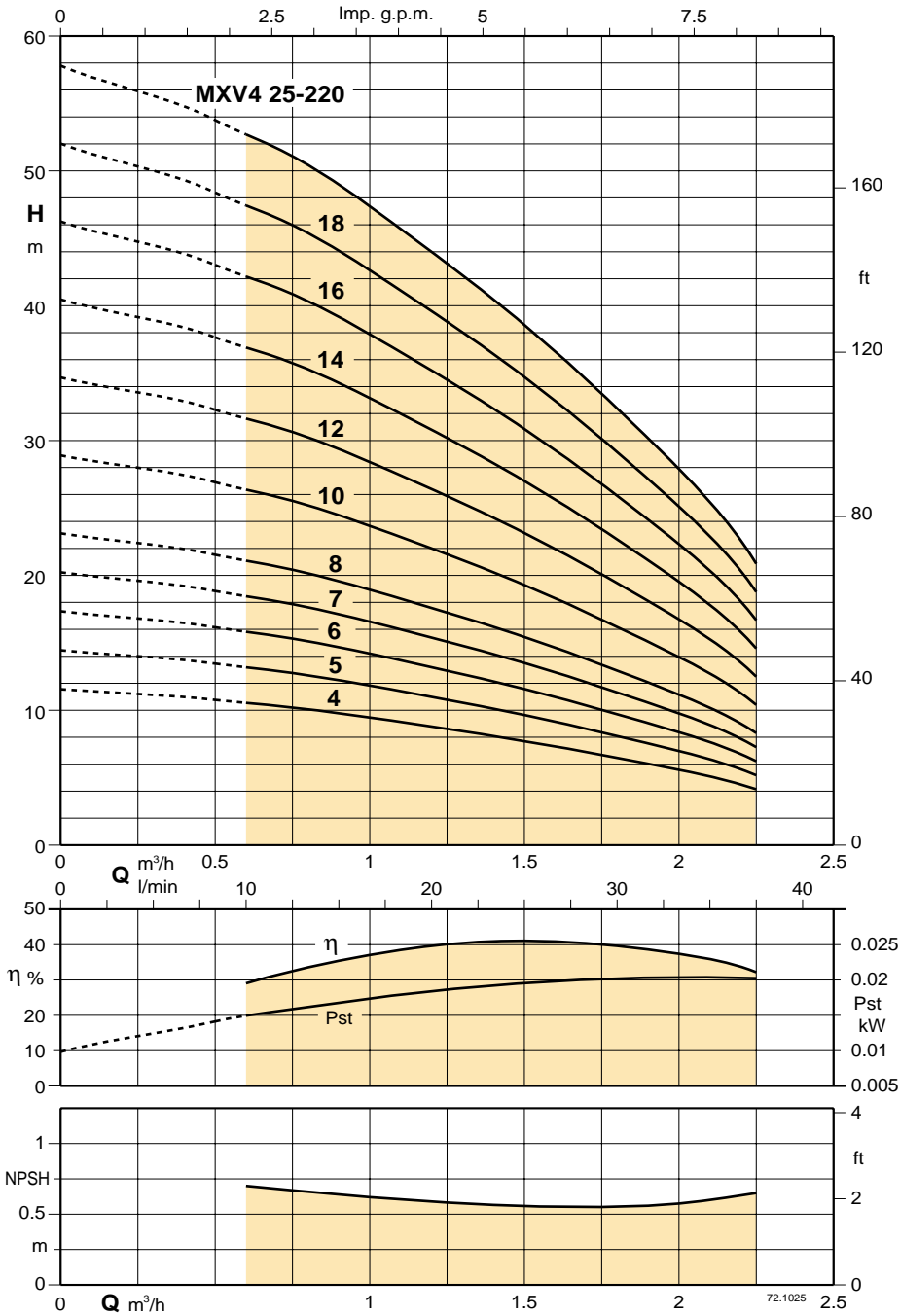

Test results with clean cold water, without gas content.

A safety margin of + 0.5 m is recommended for the NPSH value.

Tolerances in accordance with ISO 9906, Annex A.

Head and power values valid for liquids with density $\rho = 1,0 \text{ kg/dm}^3$ and kinematic viscosity $\nu = \text{max } 20 \text{ mm}^2/\text{sec}$.

Pst = Power with reference to one stage.

Pump type	Motor power		Q m ³ /h l/min	0	0,6	0,9	1,2	1,5	1,8	2,2		
	kW	HP		0	10	15	20	25	30	36,6		
MXV4 25 - 204	0,55	0,75	H m	11,5	10,5	10	9	7,5	6,5	4		
MXV4 25 - 205	0,55	0,75		14,5	13	12	11	9,5	8	5		
MXV4 25 - 206	0,55	0,75		17,5	16	14,5	13	11,5	9,5	6		
MXV4 25 - 207	0,55	0,75		20,5	18,5	17	15,5	13,5	11	7		
MXV4 25 - 208	0,55	0,75		23	21	19,5	17,5	15	13	8		
MXV4 25 - 210	0,55	0,75		29	26,5	24,5	22	19	16	10		
MXV4 25 - 212	0,55	0,75		35	31,5	29,5	26,5	23	19	12		
MXV4 25 - 214	0,55	0,75		40,5	37	34,5	31	26,5	22,5	14		
MXV4 25 - 216	0,55	0,75		46,5	42	39	35	30,5	25,5	16,5		
MXV4 25 - 218	0,55	0,75		52	47,5	44	39,5	34	29	18,5		
MXV4 25 - 220	0,55	0,75		58	52,5	49	44	38	32	21		

Characteristic curves and performance $n \approx 1450$ rpm

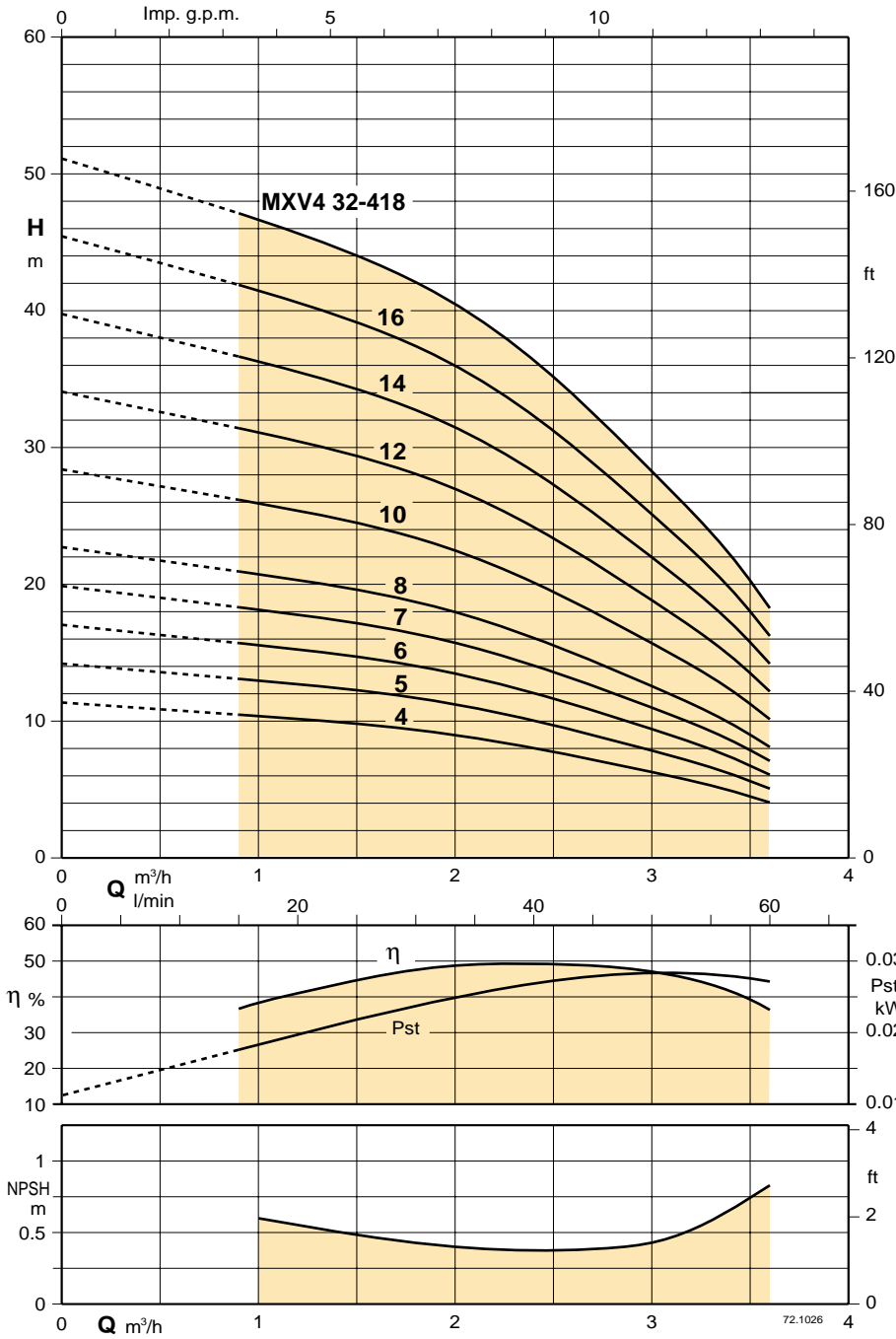

Test results with clean cold water, without gas content.

A safety margin of + 0.5 m is recommended for the NPSH value.

Tolerances in accordance with ISO 9906, Annex A.

Head and power values valid for liquids with density $\rho = 1,0$ kg/dm³ and kinematic viscosity $\nu = \max 20$ mm²/sec.

Pst = Power with reference to one stage.

Pump type	Motor power		Q m ³ /h l/min	H m								
	kW	HP		0	0,9	1,2	1,8	2,4	3	3,6		
MXV4 32 - 404	0,55	0,75	0	11	10,5	10	9,5	8	6,5	4		
MXV4 32 - 405	0,55	0,75	0	14	13	12,5	12	10	8	5		
MXV4 32 - 406	0,55	0,75	0	17	15,5	15	14	12	9,5	6		
MXV4 32 - 407	0,55	0,75	0	19,5	18	17,5	16,5	14	11	7		
MXV4 32 - 408	0,55	0,75	0	22,5	21	20	19	16	13	8		
MXV4 32 - 410	0,55	0,75	0	28	26	25	23,5	20	16	10		
MXV4 32 - 412	0,55	0,75	0	33,5	31	30	28	24	19	12		
MXV4 32 - 414	0,55	0,75	0	39	36,5	35	33	28	22,5	14		
MXV4 32 - 416	0,55	0,75	0	45	41,5	40	37,5	32	25,5	16		
MXV4 32 - 418	0,75	1	0	51	47	45	42	36	29	18		

Characteristic curves and performance $n \approx 1450$ rpm

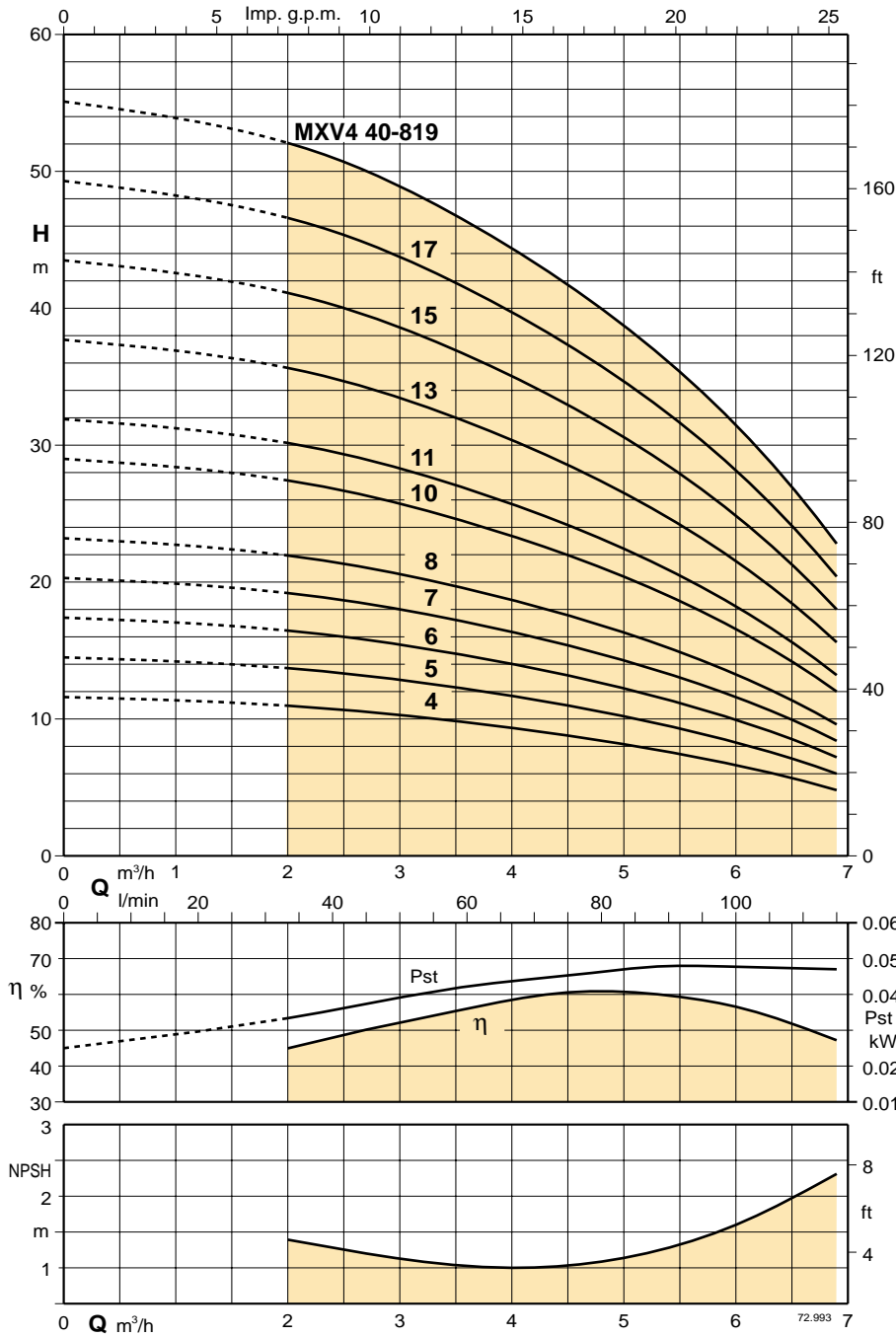

Test results with clean cold water, without gas content.

A safety margin of + 0.5 m is recommended for the NPSH value.

Tolerances in accordance with ISO 9906, Annex A.

Head and power values valid for liquids with density $\rho = 1,0 \text{ kg/dm}^3$ and kinematic viscosity $\nu = \text{max } 20 \text{ mm}^2/\text{sec}$.

Pst = Power with reference to one stage.

Pump type	Motor power		Q m ³ /h l/min	H m									
	kW	HP		0	2	2,7	3,6	4,2	4,8	5,4	6	6,9	
MXV4 40 - 804	0,55	0,75	0	11,5	11	10,5	9,5	9	8,5	7,5	6,5	5	
MXV4 40 - 805	0,55	0,75	20	14,5	14	13	12	11,5	10,5	9,5	8	6	
MXV4 40 - 806	0,55	0,75	40	17,5	16,5	16	14,5	13,5	12,5	11,5	10	7	
MXV4 40 - 807	0,55	0,75	60	20	19	18,5	17	16	15	13,5	11,5	8,5	
MXV4 40 - 808	0,55	0,75	80	23	22	21	19,5	18	17	15	13	9,5	
MXV4 40 - 810	0,75	1	100	29	27,5	26	24	23	21	19	16,5	12	
MXV4 40 - 811	0,75	1	120	32	30	29	26,5	25	23	21	18	13	
MXV4 40 - 813	0,75	1	140	38	36	34	31,5	29,5	27	25	21,5	15,5	
MXV4 40 - 815	1,1	1,5	160	43,5	41	39,5	36,5	34	31,5	28,5	25	18	
MXV4 40 - 817	1,1	1,5	180	49	47	44,5	41	39	36	32	28	20,5	
MXV4 40 - 819	1,1	1,5	200	55	52	50	46	43	40	36	31,5	23	

Characteristic curves and performance $n \approx 1450$ rpm

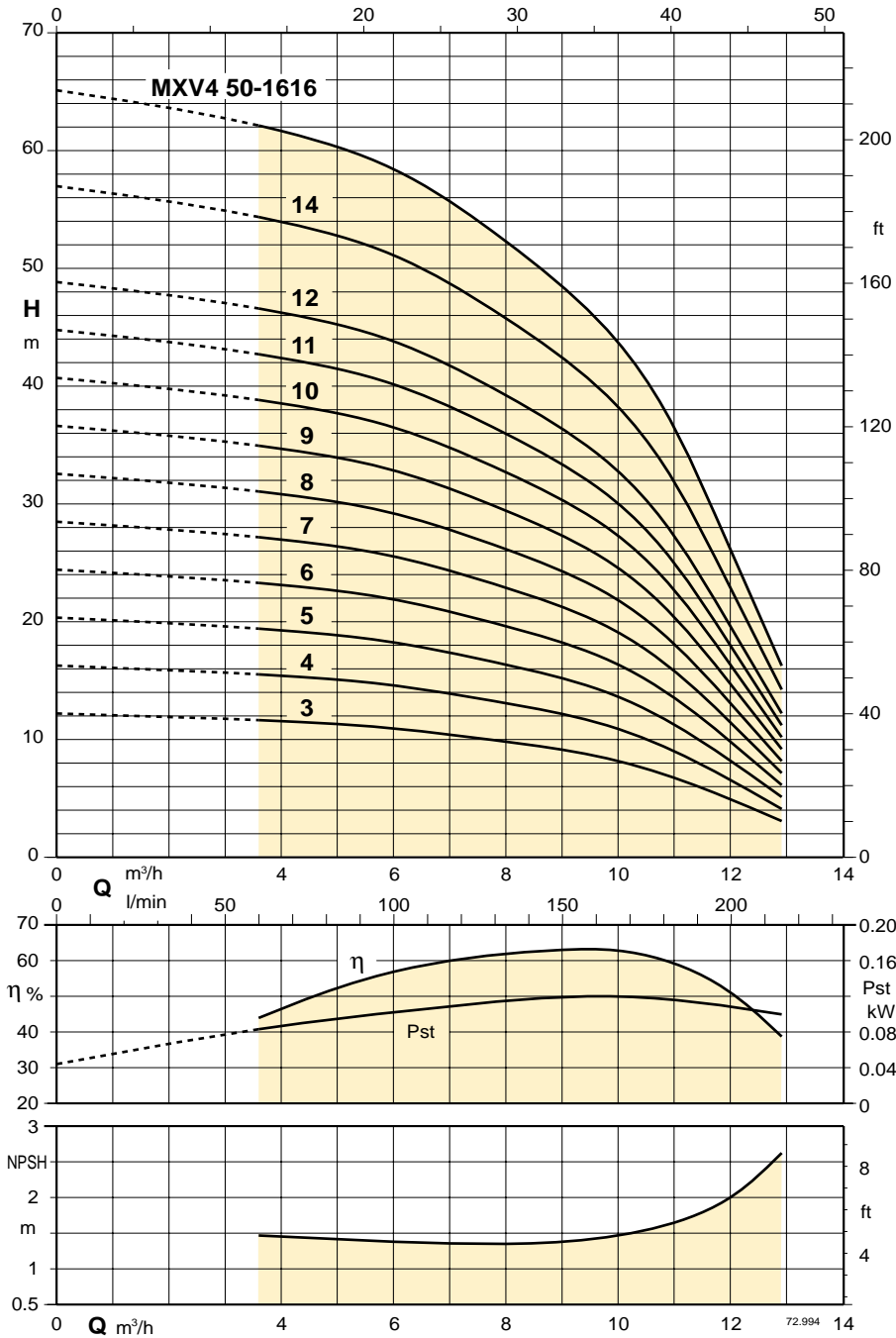

Test results with clean cold water, without gas content.

A safety margin of + 0.5 m is recommended for the NPSH value.

Tolerances in accordance with ISO 9906, Annex A.

Head and power values valid for liquids with density $\rho = 1,0 \text{ kg/dm}^3$ and kinematic viscosity $\nu = \text{max } 20 \text{ mm}^2/\text{sec}$.

Pst = Power with reference to one stage.

Pump type	Motor power		Q m³/h l/min	H m									
	kW	HP		0	3,6	4,5	6	7,5	9	10,5	12,9		
MXV4 50 - 1603	2,2	3	0	12,3	11,5	11,5	11	10	9	7,5	3		
MXV4 50 - 1604	2,2	3	60	16,5	15,5	15,5	14,5	13,5	12	10	4		
MXV4 50 - 1605	2,2	3	75	20,5	19,5	19	18,5	17	15,5	12,5	5		
MXV4 50 - 1606	2,2	3	100	24,5	23	23	22	20,5	18,5	15	6		
MXV4 50 - 1607	2,2	3	125	29	27	27	25,5	24	21,5	17,5	7		
MXV4 50 - 1608	2,2	3	150	33	31	30,5	29,5	27	24,5	20	8		
MXV4 50 - 1609	2,2	3	175	37	35	34,5	33	30,5	27,5	22,5	9		
MXV4 50 - 1610	2,2	3	215	41	39	38,5	36,5	34	30,5	25	10		
MXV4 50 - 1611	2,2	3		45	42,5	42	40,5	37,5	34	27,5	11,5		
MXV4 50 - 1612	2,2	3		49	46,5	46	44	41	37	30	12,5		
MXV4 50 - 1614	2,2	3		57,5	54	53,5	51,5	47,5	43	35	14,5		
MXV4 50 - 1616	3	4		65,5	62	61,5	58,5	54,5	49	40	16,5		

Characteristic curves and performance $n \approx 1450$ rpm

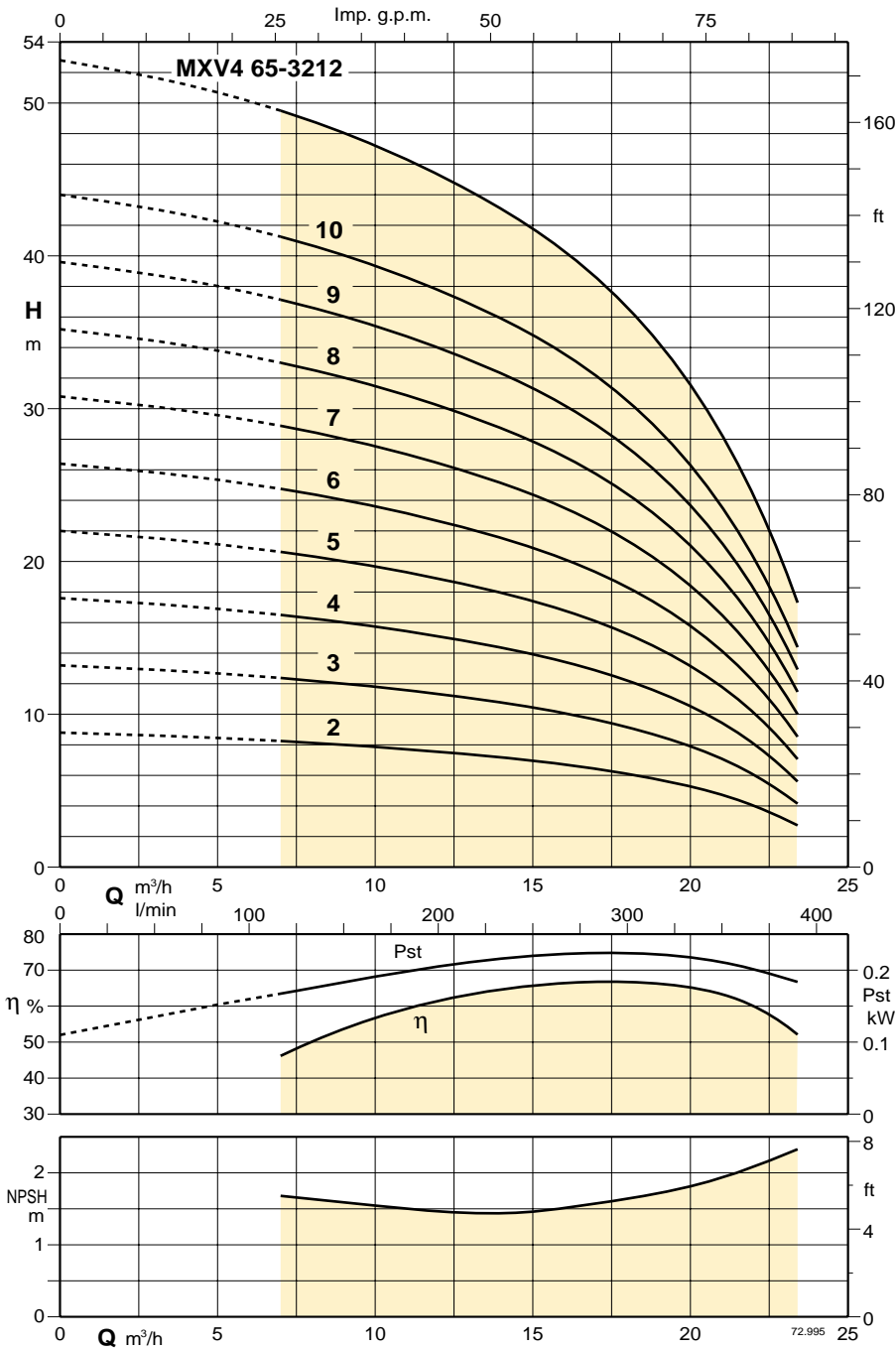

Test results with clean cold water, without gas content.

A safety margin of + 0.5 m is recommended for the NPSH value.

Tolerances in accordance with ISO 9906, Annex A.

Head and power values valid for liquids with density $\rho = 1,0 \text{ kg/dm}^3$ and kinematic viscosity $\nu = \text{max } 20 \text{ mm}^2/\text{sec}$.

Pst = Power with reference to one stage.

Pump type	Motor power		Q m³/h l/min	H m									
	kW	HP		0	7	9	11	13	15	17	19	23,4	
MXV4 65 - 3202	2,2	3	0	7	9	11	13	15	17	19	23,4		
MXV4 65 - 3203	2,2	3	0	116,6	150	183	216	250	283	316	390		
MXV4 65 - 3204	2,2	3	9	8,2	8	7,7	7,4	7	6,5	6	3		
MXV4 65 - 3205	2,2	3	13	12,3	12	11,5	11	10	9,5	8,5	4		
MXV4 65 - 3206	2,2	3	17,5	16,5	16	15,5	15	13,5	12,5	11,5	6		
MXV4 65 - 3207	2,2	3	22	20,5	20	19	18	17	16	14	7		
MXV4 65 - 3208	2,2	3	26	25	24	23	22	20,5	19	17	8,5		
MXV4 65 - 3209	3	4	31	29	28	27	25,5	24	22	20	10		
MXV4 65 - 3210	3	4	35	33	32	30,5	29,5	27	25,5	23	11,5		
MXV4 65 - 3212	4	5,5	39	37	36	34,5	33	30,5	28,5	25,5	13		
			44	41	40	38,5	36,5	34	32	28,5	14,5		
			53	49	48	46	44	41	38	34	17,5		

Characteristic curves and performance $n \approx 1450$ rpm

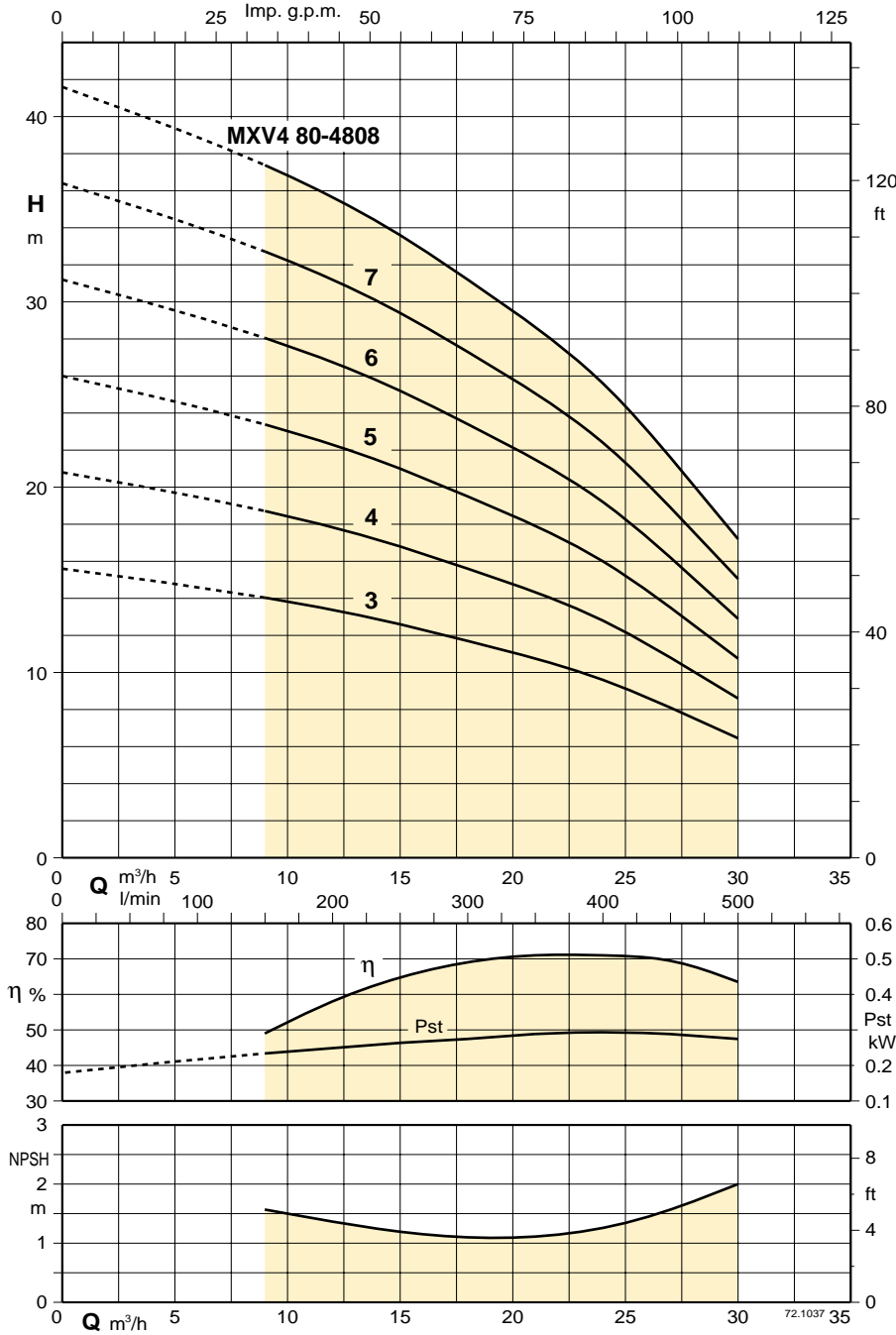

Test results with clean cold water, without gas content.

A safety margin of + 0.5 m is recommended for the NPSH value.

Tolerances in accordance with ISO 9906, Annex A.

Head and power values valid for liquids with density $\rho = 1,0 \text{ kg/dm}^3$ and kinematic viscosity $\nu = \text{max } 20 \text{ mm}^2/\text{sec}$.

Pst = Power with reference to one stage.

Pump type	Motor power		Q m³/h l/min	0	9	12	15	18	21	24	27	30	
	kW	HP		0	150	200	250	300	350	400	450	500	
MXV4 80 - 4803	2,2	3	H m	15,5	14	13	12,5	11,5	11	9,5	8	6,5	
MXV4 80 - 4804	2,2	3		21	19	18	17	15,5	14,5	13	11	8,5	
MXV4 80 - 4805	2,2	3		26	23,5	22	21	19,5	18	16	13,5	11	
MXV4 80 - 4806	2,2	3		31	28	26,5	25	23,5	21,5	19	16	13	
MXV4 80 - 4807	3	4		36,5	33	31	29,5	27	25	22,5	19	15	
MXV4 80 - 4808	3	4		41,5	37,5	35,5	33,5	31	29	25,5	21,5	17	

Dimensions and weights

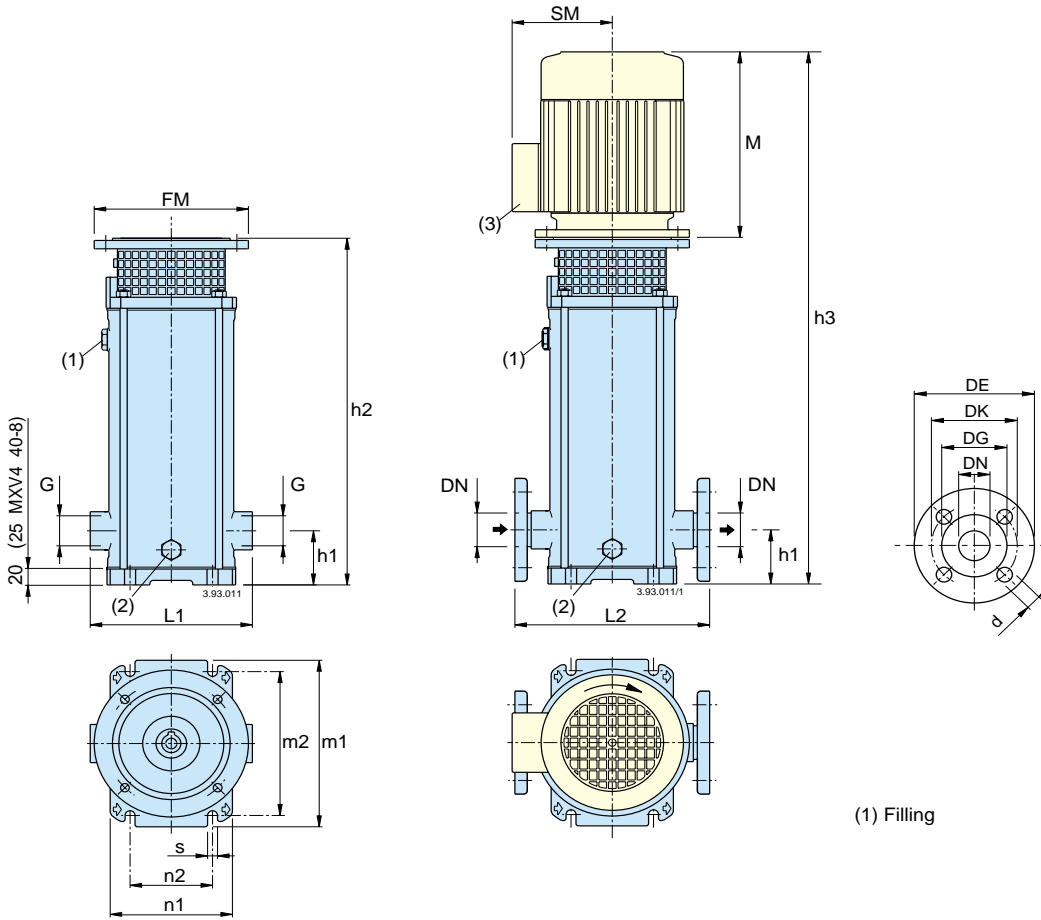

Counterflanges in stainless steel

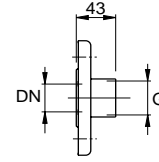

DN	G ISO 228
25	1
32	1 1/4
40	1 1/2

Flanges ISO 7005 PN 25 - 40

DN	DE	DK	DG	Holes	
				N.	Ø
25	115	85	65	4	14
32	140	100	76	4	18
40	150	110	86	4	18

(1) Filling

(2) Draining

Pump	Motor		MXV (G)		MXV (F)		mm											without motor		with motor
			threaded ports		flanged ports													MXV (G) (4)		(5)
			G ISO 228	L1	DN	L2	h1	h2	(5) M	h3	FM	(5) SM	m1	m2	n1	n2	s	kg(6)	kg(6)	
MXV4 25-204	0,55	0,75	80 A4	G1	215	25	250	75	372	234	606	200	120	210	180	150	100	12,5	18	26
MXV4 25-205	0,55	0,75	80 A4	G1	215	25	250	75	396	234	630	200	120	210	180	150	100	12,5	19	27
MXV4 25-206	0,55	0,75	80 A4	G1	215	25	250	75	420	234	654	200	120	210	180	150	100	12,5	20	28
MXV4 25-207	0,55	0,75	80 A4	G1	215	25	250	75	444	234	678	200	120	210	180	150	100	12,5	21	29
MXV4 25-208	0,55	0,75	80 A4	G1	215	25	250	75	468	234	702	200	120	210	180	150	100	12,5	22	30
MXV4 25-210	0,55	0,75	80 A4	G1	215	25	250	75	516	234	750	200	120	210	180	150	100	12,5	23	31
MXV4 25-212	0,55	0,75	80 A4	G1	215	25	250	75	564	234	798	200	120	210	180	150	100	12,5	25	33
MXV4 25-214	0,55	0,75	80 A4	G1	215	25	250	75	612	234	846	200	120	210	180	150	100	12,5	26	34
MXV4 25-216	0,55	0,75	80 A4	G1	215	25	250	75	660	234	894	200	120	210	180	150	100	12,5	28	36
MXV4 25-218	0,55	0,75	80 A4	G1	215	25	250	75	708	234	942	200	120	210	180	150	100	12,5	30	38
MXV4 25-220	0,55	0,75	80 A4	G1	215	25	250	75	756	234	990	200	120	210	180	150	100	12,5	31	39
MXV4 32-404	0,55	0,75	80 A4	G1 1/4	215	32	250	75	372	234	606	200	120	210	180	150	100	12,5	19	27
MXV4 32-405	0,55	0,75	80 A4	G1 1/4	215	32	250	75	396	234	630	200	120	210	180	150	100	12,5	20	28
MXV4 32-406	0,55	0,75	80 A4	G1 1/4	215	32	250	75	420	234	654	200	120	210	180	150	100	12,5	21	29
MXV4 32-407	0,55	0,75	80 A4	G1 1/4	215	32	250	75	444	234	678	200	120	210	180	150	100	12,5	22	30
MXV4 32-408	0,55	0,75	80 A4	G1 1/4	215	32	250	75	468	234	702	200	120	210	180	150	100	12,5	23	31
MXV4 32-410	0,55	0,75	80 A4	G1 1/4	215	32	250	75	516	234	750	200	120	210	180	150	100	12,5	25	33
MXV4 32-412	0,55	0,75	80 A4	G1 1/4	215	32	250	75	564	234	798	200	120	210	180	150	100	12,5	26	34
MXV4 32-414	0,55	0,75	80 A4	G1 1/4	215	32	250	75	612	234	846	200	120	210	180	150	100	12,5	28	36
MXV4 32-416	0,55	0,75	80 A4	G1 1/4	215	32	250	75	660	234	894	200	120	210	180	150	100	12,5	30	38
MXV4 32-418	0,75	1	80 B4	G1 1/4	215	32	250	75	708	234	942	200	120	210	180	150	100	12,5	32	42
MXV4 40-804	0,55	0,75	80 A4	G1 1/2	225	40	280	80	401	234	635	200	120	246	215	190	130	14	21	29
MXV4 40-805	0,55	0,75	80 A4	G1 1/2	225	40	280	80	431	234	665	200	120	246	215	190	130	14	22	30
MXV4 40-806	0,55	0,75	80 A4	G1 1/2	225	40	280	80	461	234	695	200	120	246	215	190	130	14	23	31
MXV4 40-807	0,55	0,75	80 A4	G1 1/2	225	40	280	80	491	234	725	200	120	246	215	190	130	14	25	33
MXV4 40-808	0,55	0,75	80 A4	G1 1/2	225	40	280	80	521	234	755	200	120	246	215	190	130	14	26	34
MXV4 40-810	0,75	1	80 B4	G1 1/2	225	40	280	80	581	234	815	200	120	246	215	190	130	14	28	38
MXV4 40-811	0,75	1	80 B4	G1 1/2	225	40	280	80	611	234	845	200	120	246	215	190	130	14	29	39
MXV4 40-813	0,75	1	80 B4	G1 1/2	225	40	280	80	671	234	905	200	120	246	215	190	130	14	31	41
MXV4 40-815	1,1	1,5	90 S4	G1 1/2	225	40	280	80	741	282	1023	200	128	246	215	190	130	14	33	46
MXV4 40-817	1,1	1,5	90 S4	G1 1/2	225	40	280	80	801	282	1083	200	128	246	215	190	130	14	35	48
MXV4 40-819	1,1	1,5	90 S4	G1 1/2	225	40	280	80	861	282	1143	200	128	246	215	190	130	14	37	50

(3) Standard position of terminal box. (for other positions rotate motor through 90° or 180°)

(4) MXV (F) = MXV (G) + 1kg

(5) With standard motor

(6) Net weight

Dimensions and weights

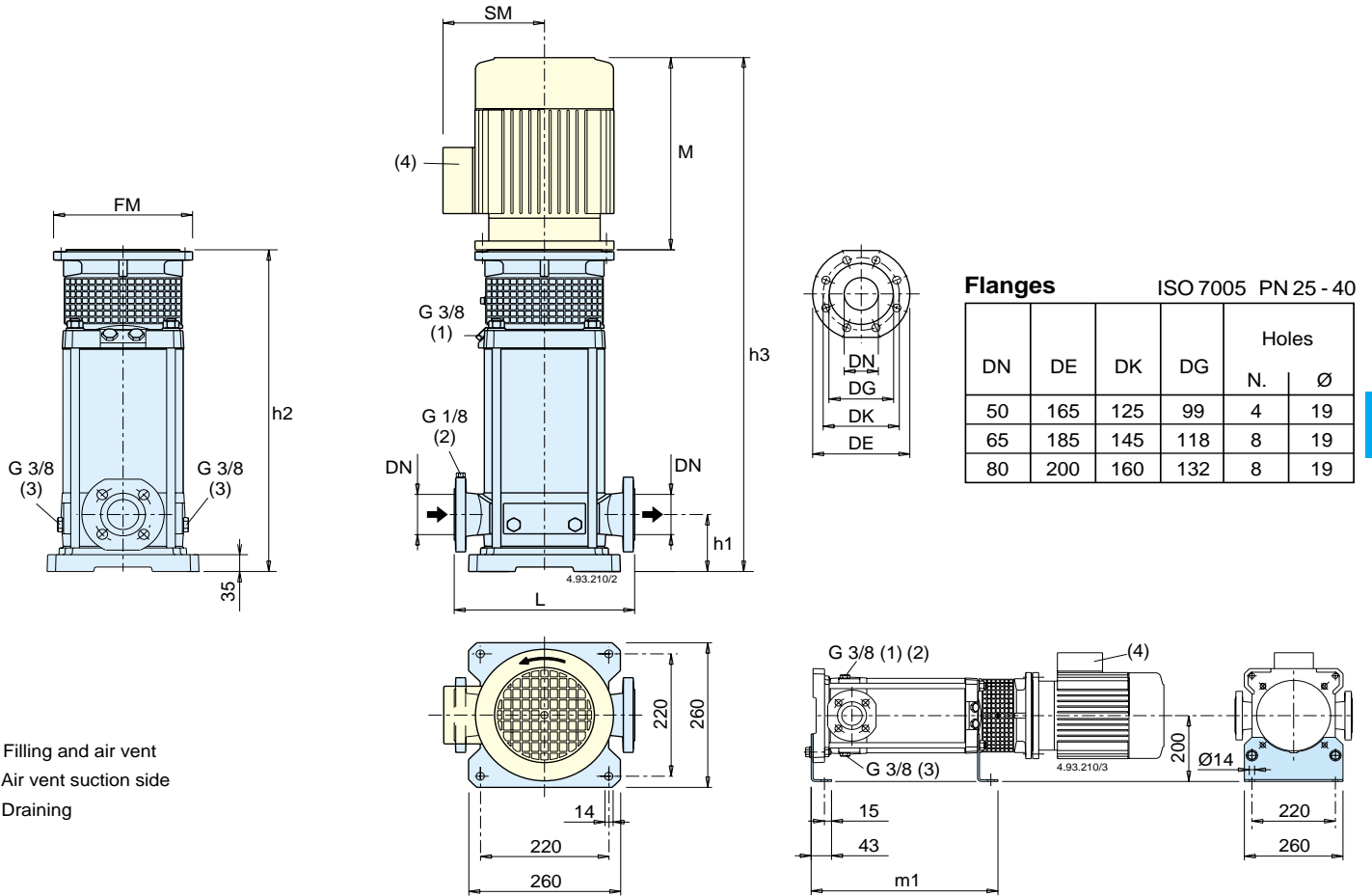

- (1) Filling and air vent
- (2) Air vent suction side
- (3) Draining

Pump	Motor		mm										without motor	with motor
	kW	HP	DN	L	h1	h2	(6) M	h3	FM	(6) SM	m1	MXV (A) (5) kg (7)	(6) kg (7)	
MXV4 50-1603	2,2	3	100 LA4	50	300	90	395	313	708	250	135	322	42	66
MXV4 50-1604	2,2	3	100 LA4	50	300	90	430	313	743	250	135	357	43	67
MXV4 50-1605	2,2	3	100 LA4	50	300	90	464	313	777	250	135	391	45	69
MXV4 50-1606	2,2	3	100 LA4	50	300	90	499	313	812	250	135	426	46	70
MXV4 50-1607	2,2	3	100 LA4	50	300	90	533	313	846	250	135	460	48	72
MXV4 50-1608	2,2	3	100 LA4	50	300	90	568	313	881	250	135	495	49	73
MXV4 50-1609	2,2	3	100 LA4	50	300	90	602	313	915	250	135	529	51	75
MXV4 50-1610	2,2	3	100 LA4	50	300	90	637	313	950	250	135	564	52	76
MXV4 50-1611	2,2	3	100 LA4	50	300	90	671	313	984	250	135	598	54	78
MXV4 50-1612	2,2	3	100 LA4	50	300	90	706	313	1019	250	135	633	55	79
MXV4 50-1614	2,2	3	100 LA4	50	300	90	775	313	1088	250	135	702	58	82
MXV4 50-1616	3	4	100 LB4	50	300	90	844	313	1157	250	135	771	61	87
MXV4 65-3202	2,2	3	100 LA4	65	320	105	407	313	720	250	135	334	45	69
MXV4 65-3203	2,2	3	100 LA4	65	320	105	453	313	766	250	135	380	47	71
MXV4 65-3204	2,2	3	100 LA4	65	320	105	499	313	812	250	135	426	49	73
MXV4 65-3205	2,2	3	100 LA4	65	320	105	545	313	858	250	135	472	51	75
MXV4 65-3206	2,2	3	100 LA4	65	320	105	591	313	904	250	135	518	52	76
MXV4 65-3207	2,2	3	100 LA4	65	320	105	637	313	950	250	135	564	54	78
MXV4 65-3208	2,2	3	100 LA4	65	320	105	683	313	996	250	135	610	56	80
MXV4 65-3209	3	4	100 LB4	65	320	105	729	313	1042	250	135	656	58	84
MXV4 65-3210	3	4	100 LB4	65	320	105	775	313	1088	250	135	702	60	86
MXV4 65-3212	4	5,5	112 M4	65	320	105	867	401	1268	250	148	794	62	92
MXV4 80-4803	2,2	3	100 LA4	80	320	105	507	313	820	250	135	434	50	74
MXV4 80-4804	2,2	3	100 LA4	80	320	105	568	313	881	250	135	495	53	77
MXV4 80-4805	2,2	3	100 LA4	80	320	105	630	313	943	250	135	557	55	79
MXV4 80-4806	2,2	3	100 LA4	80	320	105	691	313	1004	250	135	618	58	82
MXV4 80-4807	3	4	100 LB4	80	320	105	752	313	1065	250	135	679	61	87
MXV4 80-4808	3	4	100 LB4	80	320	105	814	313	1127	250	135	741	63	89

(4) Standard position of terminal box. (for other positions rotate motor through 90° or 180°)

(5) MXV (N) : + 3 kg
MXV (H) : + 3 kg

(6) With standard motor

(7) Net weight

Features

Long Service Life with Standard Motor

Pump with thrust bearing without additional axial loads on the motor bearings.

Any standard motor V1 design (suitable to be lifted in vertical position) can be used, of our choice or of Client's choice.

Easy Assembly of the Motor

With the single-piece sleeve coupling the pump unit can be supplied fully assembled also without the motor. This eliminates the risk of damage caused by shifting of the pump shaft during transportation. The motor is simply inserted in the coupling and fastened to the flange without the necessity for adapting the axial position of the pump shaft.

Extra Safety

Single-piece coupling guard to be removed only by means of a tool, positioned around the lantern bracket, thus avoiding accidental pushing and rubbing against the coupling.

Low Cost Installation

Vertical construction with reduced pump height for installation in small spaces.

In-line connections to simplify the piping layout with the possibility of inserting the pump in straight pipe-lines.

Disassembly, inspection or cleaning of internal parts without removal of piping.

Robust and Reliable

Single PN 25 construction for all pump sizes.

The suction and discharge nozzles arranged in-line absorb the forces of the piping on the pump without the creation of distorting loads causing local friction and early wears.

The lantern brackets compact and robust design maintains a sure alignment between rotating and fixed parts, reducing vibration.

The upper cover design prevents entrapment of air around the mechanical seal.

Low-Noise Operation

The water filled shroud around the stages and thick external walls, work together for low-noise operation.

Low-noise standard motor.

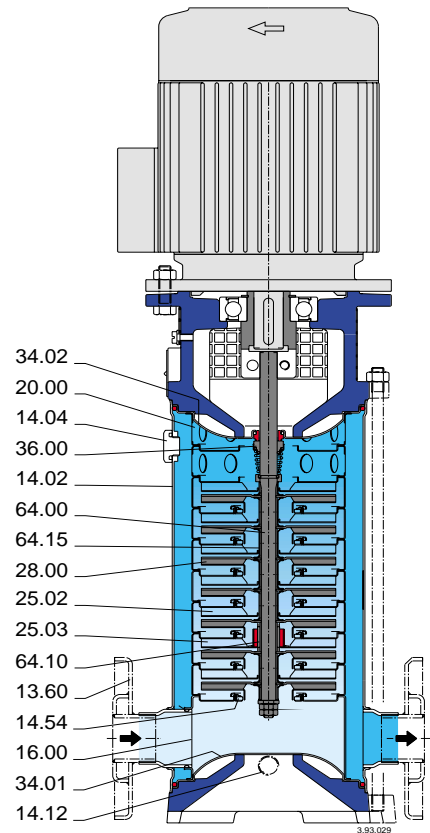

MXV 25-2, 32-4, 40-8

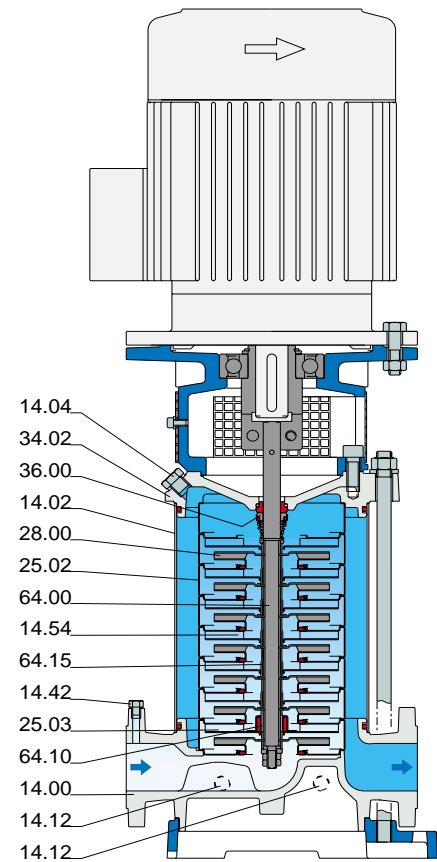

MXV 50-16, 65-32, 80-48