

Construction

Close-coupled self-priming shallow well jet pumps with built-in ejector.

Applications

- For drawing water out of a well.
- As pressure boosting pump for central water systems with low pressure (follow local specifications if increasing network pressure).
- For clean liquids or slightly dirty surface water.
- For garden use.
- For washing with a jet of water.

Operating conditions

- Liquid temperature up to 40° C.
- Ambient temperature up to 40° C.
- Maximum permissible working pressure up to 10 bar.
- Continuous duty.

Motor

- 2-pole induction motor, 50 Hz (n = 2900 rpm).
- NG:** three-phase 230/400 V ± 10%.
- NGM:** single-phase 230 V ± 10%, with thermal protector. Capacitor inside the terminal box.

- Insulation class F.
- Protection IP 54.
- Constructed in accordance with: EN 60335-2-41.

Special features on request

- Other voltages.
- Frequency 60 Hz (as per 60 Hz data sheet).
- Protection IP 55.
- Special mechanical seal
- Higher liquid or ambient temperatures.

Materials

Components	NG	B-NG
Pump casing	Cast iron GJL 200 EN 1561	Bronze G-Cu Sn 10 UNI 7013
Cover with lantern bracket		
Diffuser plate		
Impeller	Brass P- Cu Zn 40 Pb 2 UNI 5705	
Shaft	Chrome steel 1.4104 EN 10088 AISI 430	Chrome-nickel steel 1.4401 EN 10088 AISI 316
Diffuser	Polycarbonate	
Ejector	Polycarbonate	
Mechanical seal	Carbon - Ceramic - NBR	

Characteristic Curves for suction lift $H_s = 1$ m $n \approx 2900$ rpm

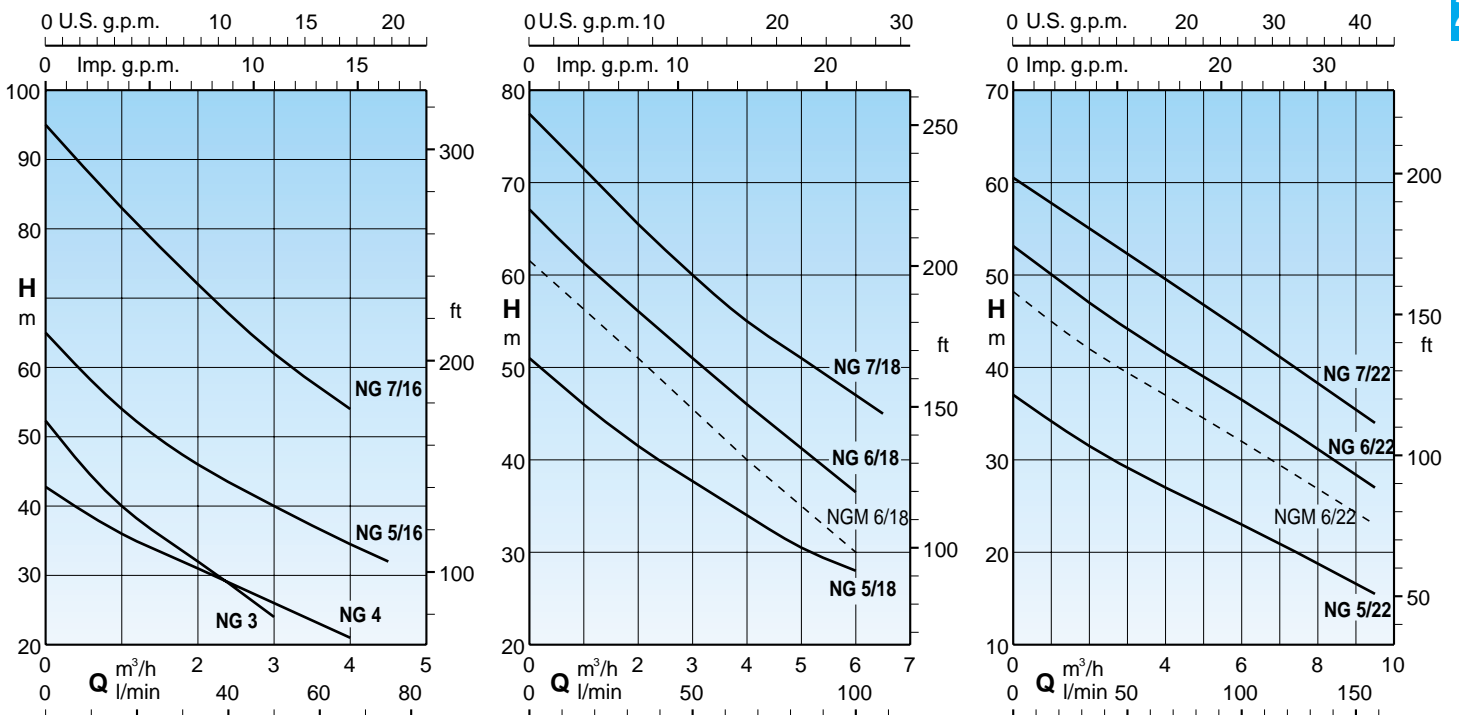

Performance for suction lift $H_s = 1\text{ m}$ $n \approx 2900\text{ rpm}$

3 ~	230V 400V		1 ~	230V		P ₂		Q	H																		
	A	A		A	kW	kW	HP		m ³ /h	m																	
								l/min	0,25	0,5	1	1,5	2	2,5	3	3,5	4	4,5	5	5,5	6	6,5	7	8	9	9,5	
NG 3E B-NG 3E	3	1,7	NGM 3E B-NGM 3E	4,5	0,9	0,55	0,75	49	45,5	40	36	32	28	24													
NG 4E B-NG 4E	3,7	2,2	NGM 4E B-NGM 4E	5,7	1	0,75	1	41	39	36	33	31	29	26	24	21											
B-NG 5/16E	5	2,9	B-NGM 5/16E	7,4	1,64	1,1	1,5	59	54	50	46	43	40	37	34,5	32											
B-NG 5/18E	5	2,9	B-NGM 5/18E	7,4	1,68	1,1	1,5	48,5	46	43,5	41,5	39,5	38	35,5	34	32	30,5	29	28								
B-NG 5/22E	5	2,9	B-NGM 5/22E	7,4	1,55	1,1	1,5	35,5	34,5	33	31,5	30,5	29,5	28	27	26	25	23,5	23	21,5	20,5	18,5	16,5	15,5			
B-NG 6/18E	7,5	4,3				1,5	2	64,5	62	59	56	54	51	48,5	46	43,5	41,5	39	36,5								
			B-NGM 6/18E	9,2	2	1,5	2	59	57	54	51	48	45	43	40	37,5	35	33	30								
B-NG 6/22E	7,5	4,3				1,5	2	51,5	50	48,5	47	46	44,5	43	41,5	40	39	37,5	36,5	35	33,5	31	28,5	27			
			B-NGM 6/22E	9,2	2	1,5	2	47	45	43,5	42	41	40	38	37	36	35	33	32	31	30	27	24	23			
B-NG 7/16E	9,15	5,3				2,2	3	89	83	77	72	67	62	58	54												
B-NG 7/18E	9,15	5,3				2,2	3	74,5	71,5	68,5	65,5	63	60	57,5	55	53	51	49	47	45							
B-NG 7/22E	9,15	5,3				2,2	3	59	57,5	56,5	55	54	52,5	51	50	48,5	47	45,5	44	42,5	41,5	38	35	34			

P1 Max. power input.

P2 Rated motor power output.

B-NG, B-NGM = Bronze construction.

Tolerances according to ISO 9906, annex A.

Installation examples

Positive suction head operation

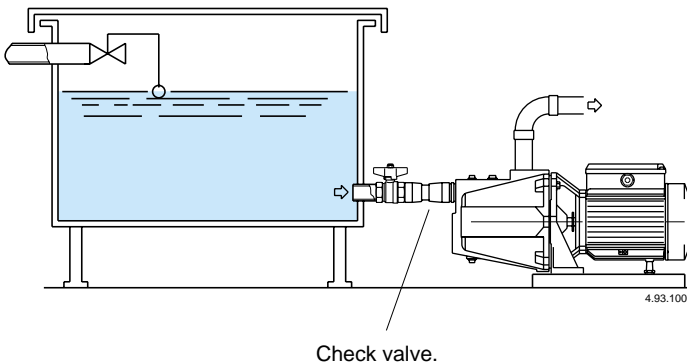

Suction lift operation

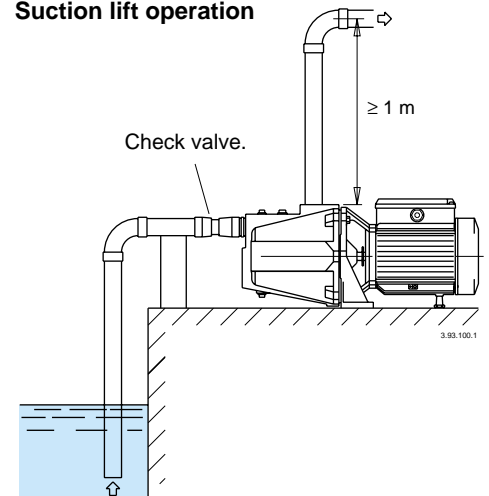

Dimensions and weights

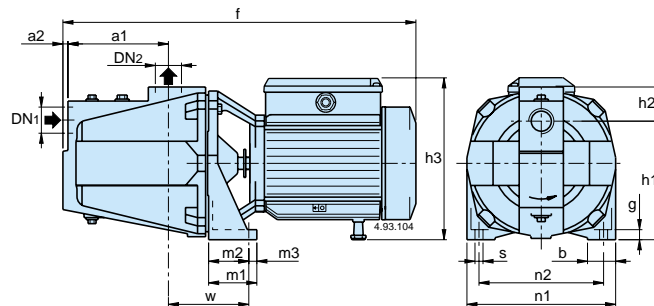

TYPE	DN ₁	DN ₂	mm															kg		
			ISO 228	a1	a2	f	h1	h2	h3	m1	m2	m3	n1	n2	b	s	w	g	NG	B-NG
NG 3E NG 4E	B-NG 3E B-NG 4E	G 1	G 1	127	8	430	150	43	203	60	52	8	185	155	35	9,5	100	11	18,4	20,8
NG 5E NG 6E NG 7E	B-NG 5E B-NG 6E B-NG 7E	G 1 1/2	G 1	160	10	560	165	57	197	60	50	10	215	175	40	11,5	115	11	29,2	31,6
																			30,8	32,9
																			31,3	33,4

Characteristic curves $n \approx 2900$ rpm

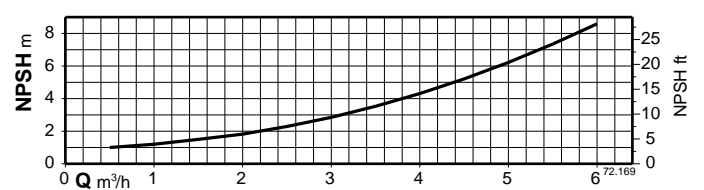
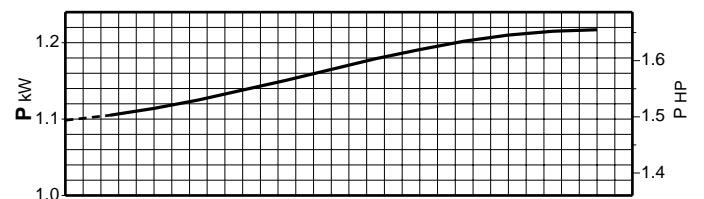
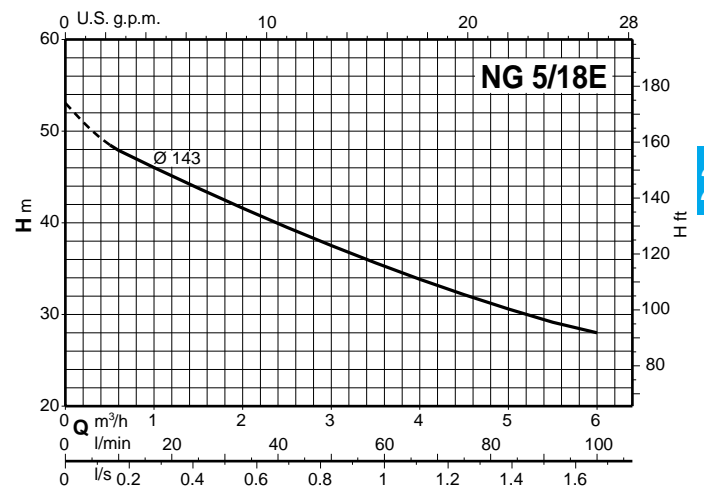
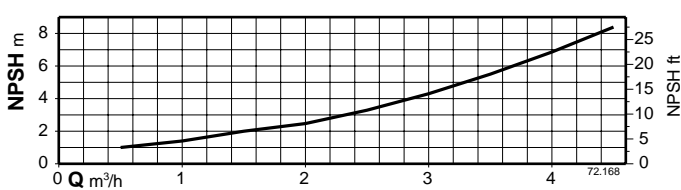
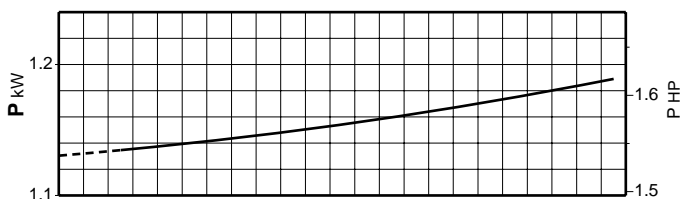
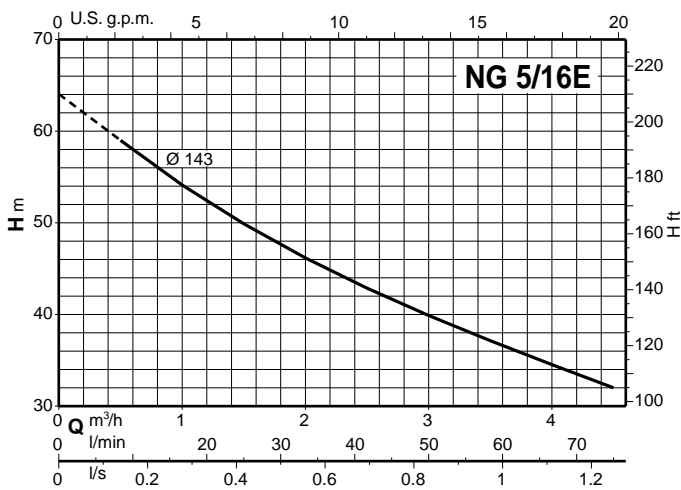
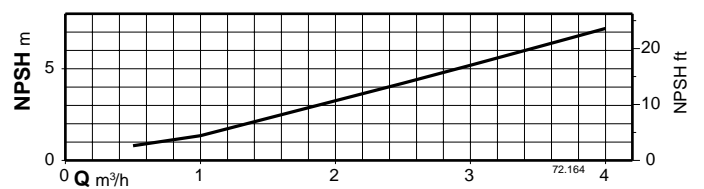
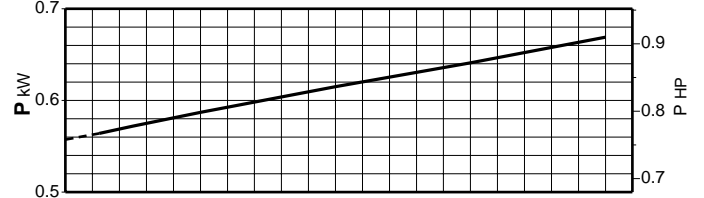
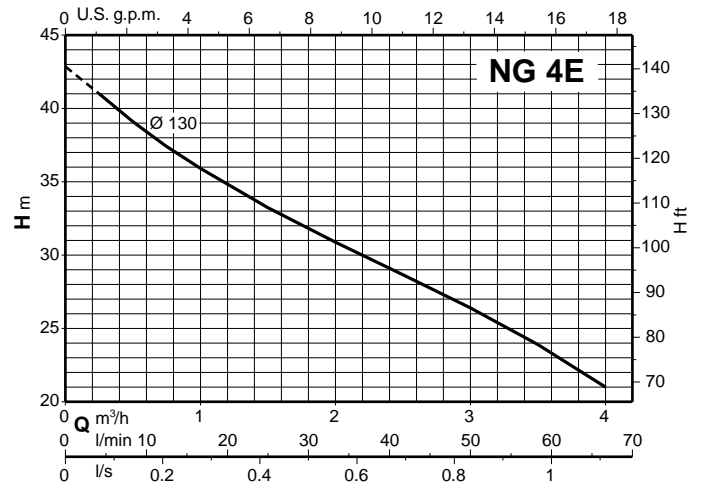
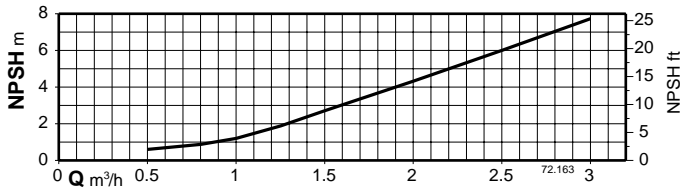
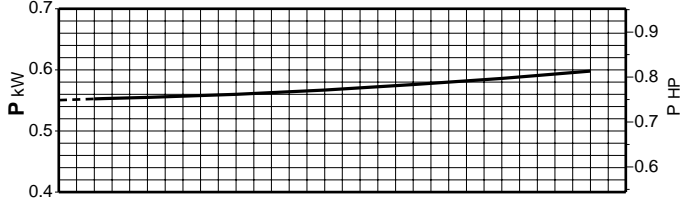
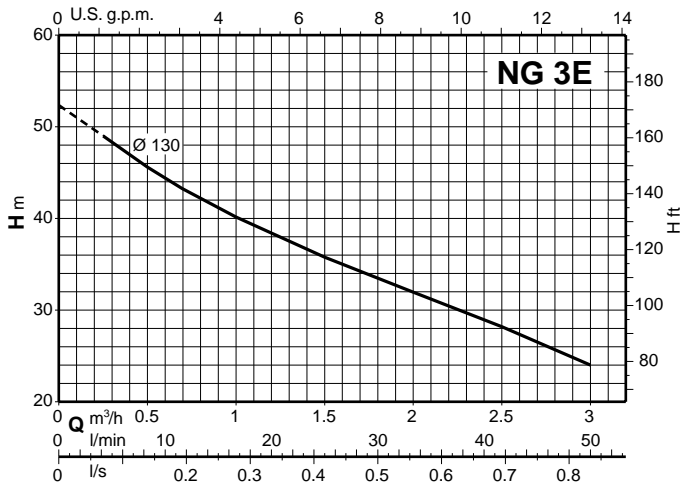

Characteristic curves $n \approx 2900$ rpm

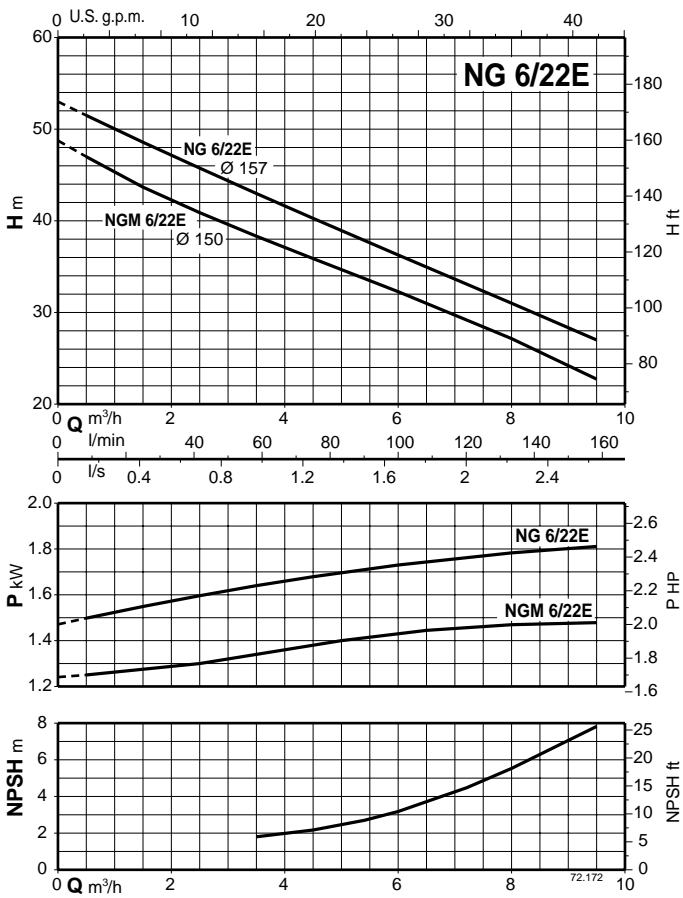
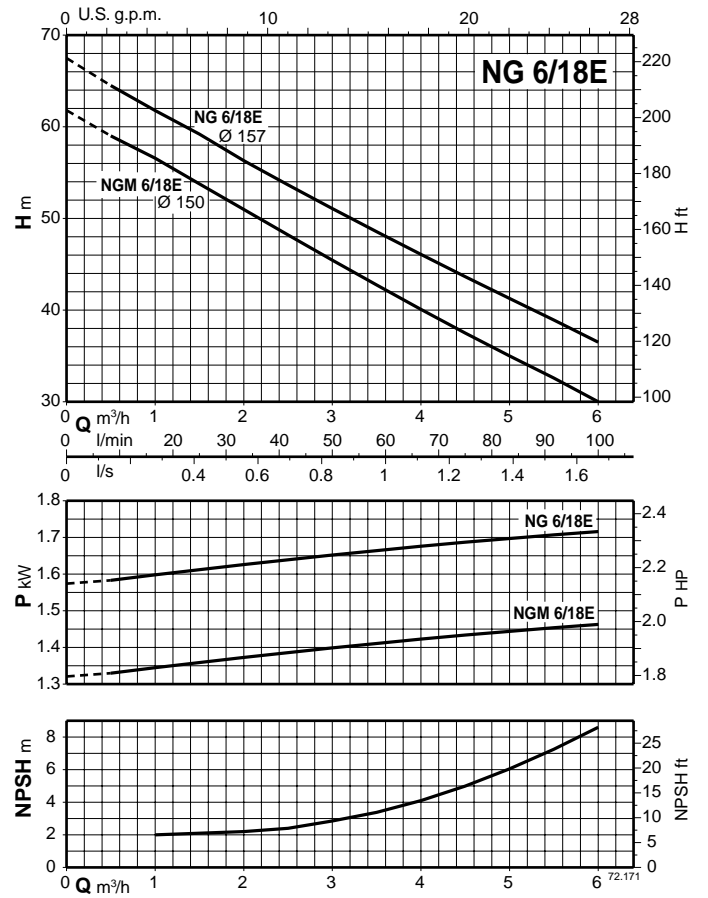
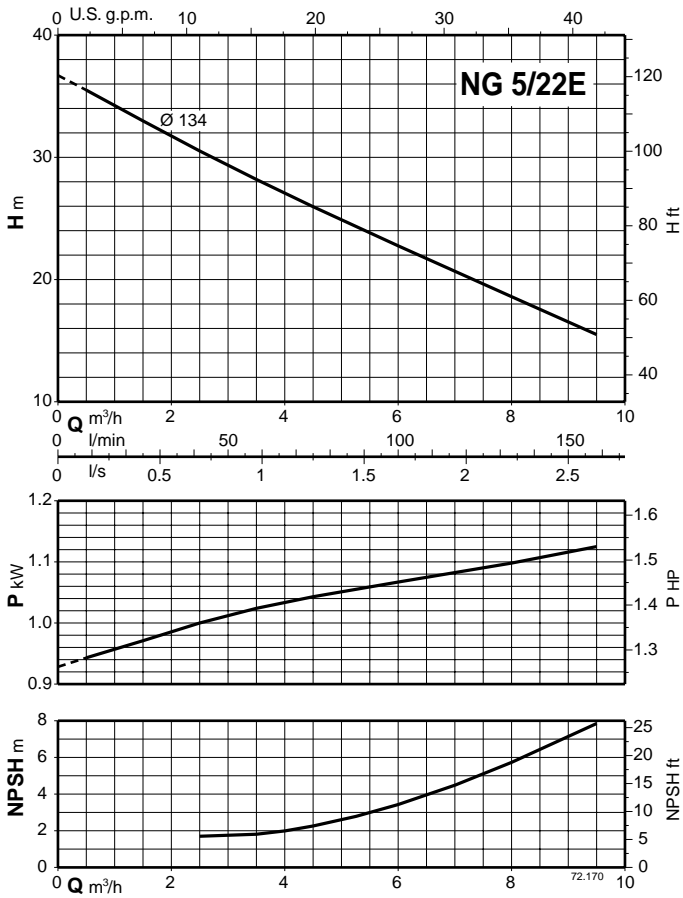

Characteristic curves $n \approx 2900$ rpm

