



### Construction

Vertical column sump pumps, with motor in dry installation and with pump body submerged in the liquid handled (without suction line or foot valve).

**Impeller** - VAL: free-flow impeller (vortex or recessed impeller).  
 - SC: open impeller.

**Connection** - VAL 30, SC 30, SC 50: threaded port ISO 228 (BS 2779).  
 - VAL 65: flange with plain face oval threaded counter-flange UNI 2245, PN 2,5.

### Applications

- For draining a basin or a sump with domestic or industrial sewage.  
 - For slightly dirty waste water, for liquids which are non-aggressive for the pump materials.

### Operating conditions

Liquid temperature up to 40° C.  
 Ambient temperature up to 40° C.  
 Continuous duty.  
 Maximum size of solids: VAL 30 = 25 mm; VAL 65 = 50 mm;  
 SC 30 = 3 mm; SC 50 = 6 mm.

### Motor

2-pole induction motor, 50 Hz (n = 2900 rpm).  
**VAL -SC:** three-phase 230/400 V ± 10%.  
**VALM-SCM:** single-phase 230 V ± 10%, with thermal protector.  
 Insulation class F.  
 Protection IP 54.  
 Constructed in accordance with IEC 34.

### Special features on request

- Other voltages.
- Frequency 60 Hz (as per 60 Hz data sheet).
- Protection IP 55.
- Bronze bearing bush (for liquid up to 100° C).
- Higher or ambient temperatures.

### Materials

Components	VAL	SC
Pump casing Lower bearing housing*	Cast iron GJL 200 EN 1561	Cast iron GJL 200 EN 1561
Impeller	Brass P-Cu Zn 40 Pb 2 UNI 5705 for VAL 30	Brass P-Cu Zn 40 Pb 2 UNI 5705
	Cast iron GJL 200 EN 1561 for VAL 65	
Shaft	Steel C 40 UNI 7231	
Bearing bush	Tecopolymer	
Shaft sleeve	Chromate bronze for VAL 65	-

\* Not existing for VAL 30.

### Characteristic Curves $n \approx 2900 \text{ rpm}$

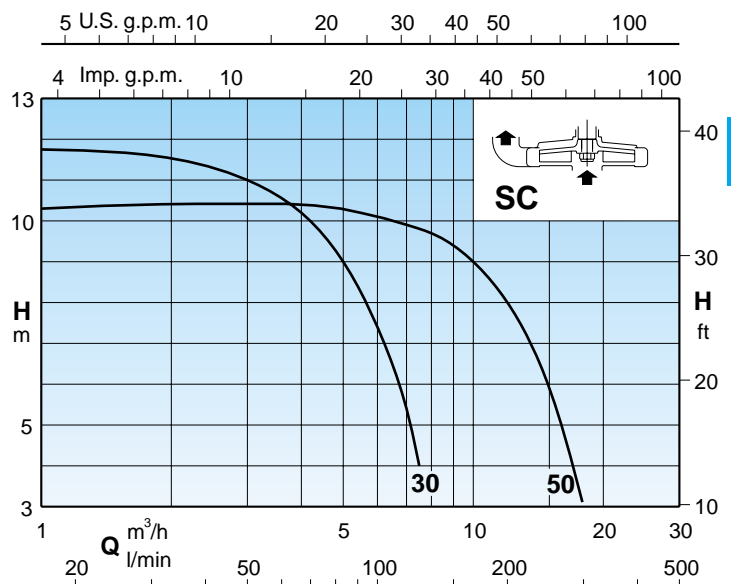
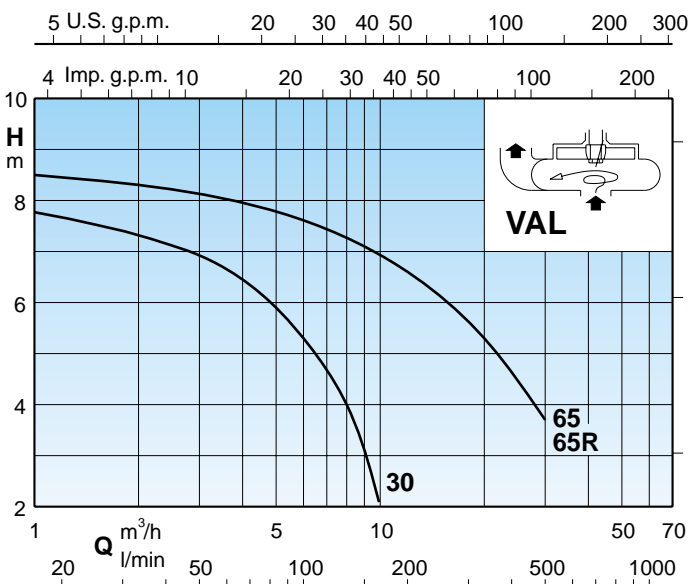

### Performance $n \approx 2900$ rpm

3 ~	230V 400V		1 ~	230V		P <sub>1</sub>	P <sub>2</sub>	Q																						
	A	A		A	kW				kW	HP	m <sup>3</sup> /h	l/min	3	3,5	4	4,5	5	5,5	6	6,5	7	7,5	8	9	10	12	14	16	18	20
VAL 30E	2,3	1,3	VALM 30E	3,6	0,63	0,45	0,6	H m	50	58,3	66,6	75	83,3	91,6	100	108	116	125	133	150	166	200	233	266	300	333	416	500		
VAL 65E	7,5	4,3				1,5	2		6,7	6,5	6,2	5,9	5,6	5,3	5	4,7	4,3	4	3	2	7,1	6,9	6,6	6,3	6	5,6	5,3	4,5	3,7	
VAL 65-RE	9,15	5,3				2,2	3														7,1	6,9	6,6	6,3	6	5,6	5,3	4,5	3,7	
SC 30E	2,3	1,3	SCM 30E	2,8	0,47	0,37	0,5		11	10,6	10,2	9,6	9	8,3	7,4	6,5	5,4	4												
SC 50E	2,3	1,3	SCM 50E	3,6	0,69	0,45	0,6						10,3	10,2	10,1	10	9,9	9,8	9,7	9,4	9	8	6,7	5	3					

P1 Max. power input.

P2 Rated motor power output.

H Total head in m.

Tolerances according to ISO 9906, annex A.

### Dimensions and weights

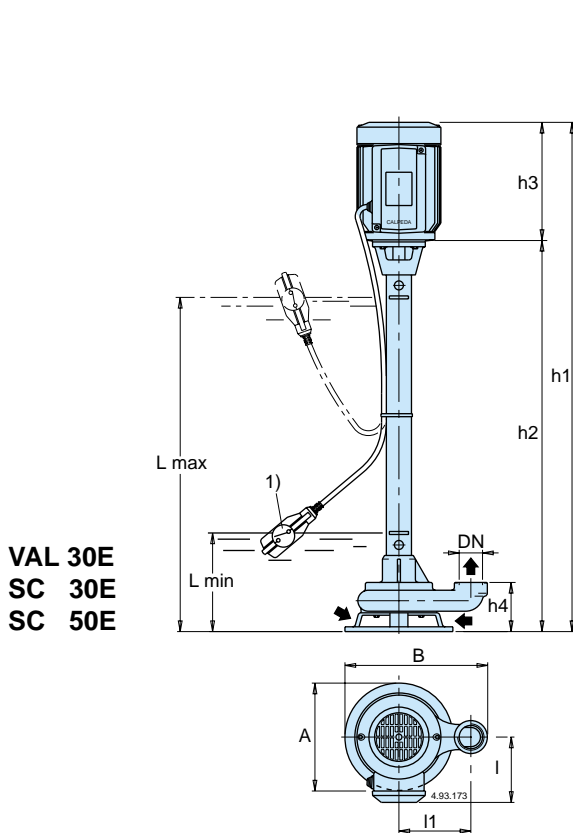

VAL 30E  
SC 30E  
SC 50E

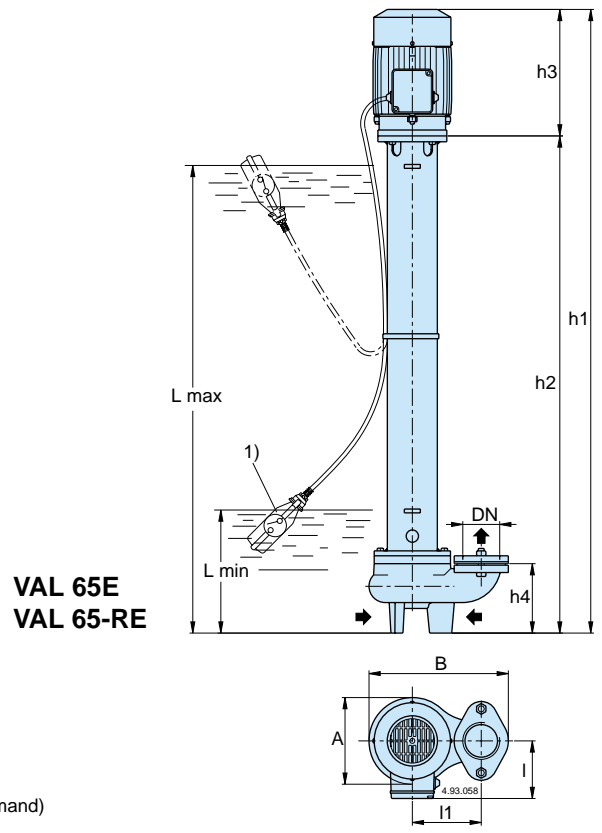

VAL 65E  
VAL 65-RE

1) Float switch (on demand)

TYPE	DN ISO 228	mm										kg
		h1	h2	h3	h4	l	l1	L min	L max	A	B	
VAL 30/750E	G 1 1/4	1025	825	200	82	105	120	150	750	180	235	17,8
VAL 30/1000E		1275	1075						1000			19,5
VAL 65/1000E - VAL 65/1000-RE	G 2 1/2	1245	1010	235	140	117	140	250	950	175	283	40
VAL 65/1500E - VAL 65/1500-RE		1745	1510						1450			48
VAL 65/2000E - VAL 65/2000-RE		2245	2010						1950			56
VAL 65/2500E - VAL 65/2500-RE		2745	2510						2450			64
SC 30/500E		765	565						455			17,4
SC 30/750E	G 1 1/4	1015	815	200	105	105	100	200	705	132	192	19,6
SC 30/1000E		1265	1065						955			21,8
SC 30/1250E		1515	1315						1205			24
SC 50/500E		780	580						470			18,5
SC 50/750E	G 2	1030	830	200	120	105	120	215	720	173	243	20,7
SC 50/1000E		1280	1080						970			22,9
SC 50/1250E		1530	1330						1220			25,1